

**Authorized Technician**

# **SERVICE & REPAIR MANUAL**



# **H.A.B.D.**

**(Helicopter Aircrew Breathing Device)**

REVISED 02/11

## COPYRIGHT NOTICE

This owner's manual is copyrighted, all rights reserved. It may not, in whole or in part, be copied, photocopied, reproduced, translated, or reduced to any electronic medium or machine readable form without prior consent in writing from Aqua Lung America, Inc.

**©2011 AQUA LUNG AMERICA.  
HABD TECHNICAL MANUAL, P/N 780303**

You can contact a Technical Adviser via e-mail at:

rbedard@aqualung.com  
dstancil@aqualung.com  
dsumian@aqualung.com

## TRADEMARK NOTICE

Aqua Lung America<sup>®</sup>, is a registered trademark of Aqua Lung America, Inc.

## Warnings, Cautions, & Notes

PAY SPECIAL ATTENTION TO INFORMATION PROVIDED IN WARNINGS, CAUTIONS AND NOTES THAT ARE ACCOMPANIED BY ONE OF THESE SYMBOLS:



A **WARNING** indicates a procedure or situation that, if not avoided, could result in serious injury or death to the user.



A **CAUTION** indicates any situation or technique that could cause damage to the product, and could subsequently result in injury to the user.



A **NOTE** is used to emphasize important points, tips and reminders.

## Table of Contents

<b>Change Record</b> .....	<b>4</b>
<b>Introduction</b> .....	<b>5</b>
<b>Initial Inspection Procedure</b> .....	<b>6</b>
External Inspection .....	6
Immersion / Leak Test .....	6
Intermediate (Over-Bottom) Pressure Test .....	7
<b>Disassembly Procedures</b> .....	<b>7</b>
First Stage Disassembly .....	7
Cylinder Adapter Disassembly .....	10
Second Stage Disassembly (Left Hand Model) .....	10
Second Stage Disassembly (Right Hand Model) .....	12
<b>Reassembly Procedures</b> .....	<b>15</b>
Cylinder Adapter Reassembly .....	15
First Stage Reassembly .....	15
Second Stage Reassembly (Left and Right Hand Model) .....	17
Second Stage Reassembly (Left Hand Model) .....	18
Second Stage Reassembly (Right Hand Model) .....	20
<b>Final Adjustment &amp; Testing Procedures</b> .....	<b>22</b>
First Stage Adjustment .....	22
Second Stage Adjustment .....	24
Final Assembly - Second Stage (RH & LH Models) .....	25
Final Testing Procedures .....	25
Pressure Gauge Installation & External Leak Test .....	26
<b>Table 1 - Troubleshooting Guide - Second Stage</b> .....	<b>27</b>
<b>Table 2 - Troubleshooting Guide - First Stage / Valve Assembly</b> .....	<b>29</b>
<b>Table 3 - Recommended Tool List</b> .....	<b>30</b>
<b>Table 4 - Standard Parts Replacement Schedule</b> .....	<b>31</b>
<b>Table 5 - Torque Specifications</b> .....	<b>31</b>
<b>Table 6 - Test Bench Specifications</b> .....	<b>32</b>
<b>Procedure A - Cleaning &amp; Lubrication</b> .....	<b>33</b>
<b>Table A - Recommended Lubricants &amp; Cleaners</b> .....	<b>34</b>
<b>Exploded Diagram - First Stage with Cylinder Assembly</b> .....	<b>35</b>
<b>Exploded Diagram - Second Stage (LH Version)</b> .....	<b>36</b>
<b>Exploded Diagram - Second Stage (RH Version)</b> .....	<b>37</b>
<b>Maintenance Notes</b> .....	<b>38</b>

**CHANGE RECORD**

<b>Change No.</b>	<b>Date</b>	<b>Title and/or brief description</b>	<b>Change made by</b>
10-001	3 NOV 10	Adjustment screw (11) clarification	AQA

## Introduction

This manual provides factory prescribed procedures for the correct service and repair of the Helicopter Aircrew Breathing Device (H.A.B.D.). It is not intended to be used as an instructional manual for untrained personnel. The procedures outlined within this manual are to be performed only by personnel who have received factory authorized training through an Aqua Lung® Service & Repair Seminar.

If you do not completely understand all of the procedures outlined in this manual, contact Aqua Lung® to speak directly with a Technical Advisor before proceeding any further.

## Warnings, Cautions, & Notes

Pay special attention to information provided in warnings, cautions, and notes that are accompanied by one of these symbols :



**A WARNING** indicates a procedure or situation that may result in serious injury or death if instructions are not followed correctly.



A **CAUTION** indicates any situation or technique that will result in potential damage to the product, or render the product unsafe if instructions are not followed correctly.



A **NOTE** is used to emphasize important points, tips, and reminders.

## Scheduled Service

The H.A.B.D. should be given the same care and maintenance as life support equipment. It is therefore important to perform scheduled overhaul service for the complete unit, according to the procedures outlined in this manual on a regularly scheduled basis; **at least once a year** with normal use.



**NOTE:** H.A.B.D. units manufactured prior to September 1, 1999 may require the installation of the SRU40A/P Extreme Weather Retrofit Kit (PN 1006-99), in addition to the mandatory replacement parts provided in the H.A.B.D. overhaul parts kits. This manual contains important information regarding the proper identification of certain components to help determine whether this retrofit may be needed.

## General Guidelines

1. In order to correctly perform the procedures outlined in this manual, it is important to follow each step exactly in the order given. Read over the entire manual to become familiar with all procedures before attempting to disassemble the H.A.B.D., and to learn which specialty tools and replacement parts will be required. Keep the manual open beside you for reference while performing each procedure. Do not rely on memory.
2. All service and repair should be carried out in a work area specifically set up and equipped for the task. Adequate lighting, cleanliness, and easy access to all required tools are essential for an efficient repair facility.
3. Before beginning any disassembly, it is important to first perform the Initial Inspection procedure, and refer to **Table 1 - Troubleshooting** to determine the possible cause of any symptoms which may be present.
4. As each unit is disassembled, reusable components should be segregated and not allowed to intermix with non-reusable parts or parts from other units. Delicate parts, including inlet fittings and crowns which contain critical sealing surfaces, must be protected and isolated from other parts to prevent damage during the cleaning procedure.
5. Use only genuine Aqua Lung® parts provided in the H.A.B.D. overhaul parts kits. DO NOT attempt to substitute an Aqua Lung® part with another manufacturer's, regardless of any similarity in shape or size. Substitution with other manufacturer's parts constitutes an after-market modification of the product, and renders all warranties null and void.
6. Do not attempt to reuse mandatory replacement parts under any circumstances, regardless of the amount of use the product has received since it was manufactured or last serviced.
7. When reassembling, it is important to follow every torque specification prescribed in this manual, using a calibrated torque wrench. Most parts are made of either marine brass or plastic, and can be permanently damaged by undue stress.

## Initial Inspection Procedure

### EXTERNAL INSPECTION

1. When possible, inspect the filter of the fill adapter which has been used to fill the H.A.B.D. to check for any signs that contaminants, such as moisture or particulate matter, may have entered the system from the charging system.
2. Visually inspect the condition of the IP hose along its length to check for any signs of deterioration or damage, such as blistering and abrasion, and corrosion of the fittings.
3. Closely examine the chrome finish of the first stage to check for any flaking, chipping, or other damage to the chrome.



**CAUTION:** Ultrasonic cleaning may cause further chrome loss for parts which show damage to their chrome finish. This loss DOES NOT render the part unusable.

4. While holding the first stage secure, slowly turn the H.A.B.D. cylinder counterclockwise only until the indicator pin can be sighted through the small aperture marked "ON" (see Figure 1).
5. While the valve is in the "ON" position, examine the pressure gauge to determine whether the needle is within the green zone, indicating that the H.A.B.D. cylinder is full (see Figure 2).

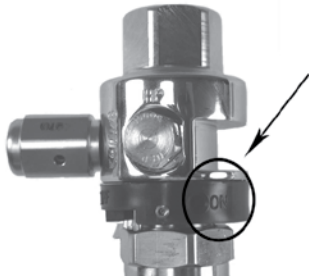

Figure 1 - "ON" position



Figure 2 - "Full" indication



**NOTE:** If the pressure gauge does not indicate that the cylinder is completely full, it will be necessary to perform the filling procedure outlined in the H.A.B.D. Owner's Manual before proceeding further.



**WARNING:** The H.A.B.D. is designated compatible for use only with normal, atmospheric compressed air (21% oxygen and 79% nitrogen by volume). DO NOT attempt to fill with pure oxygen, or enriched air which contains more than 23.5% oxygen. Failure to observe this warning may result in serious injury or death due to fire and explosion, or the serious deterioration and failure of the equipment.

### IMMERSION / LEAK TEST

1. After ensuring that the system is pressurized and the cylinder is full, listen for any obvious signs of leakage from the system, including freeflow from the second stage.



**CAUTION:** If leakage from the second stage is detected, it should be presumed that the first stage intermediate pressure exceeds 160 psi. In this event, DO NOT attempt to perform the intermediate pressure test. Doing so may cause damage to the test gauge, and possibly result in serious personal injury.

2. If leakage cannot be heard, or if the source of leakage detected audibly is not obvious, immerse the entire system in fresh water. Examine closely to check for any bubble streams to locate the source of any leakage.
3. Note the source of any leakage found and refer to **Table 1 - Troubleshooting** to determine its possible cause.
4. Turn the valve to the "OFF" position and depress the second stage purge to completely depressurize the system (see Figure 3). Wait at least five minutes, and depress the second stage purge to determine whether any significant air pressure has built up inside the IP hose and second stage valve.



Figure 3 - "OFF" position



**CAUTION:** Do not turn the first stage any further than is necessary to shut the valve. Doing so may cause premature wear or damage to the main valve and indicator pin.



**NOTE:** If a buildup of air pressure occurs inside the IP hose and second stage valve after the H.A.B.D. valve has been turned to the "OFF" position and the system has been depressurized, the valve body (28) must be replaced with new.

## INTERMEDIATE (OVER-BOTTOM) PRESSURE TEST

1. Depress the second stage purge to determine once again that the system is not pressurized. While holding the hex nut (27) of the second stage secure with a 13/16" open-end wrench, apply an 11/16" open-end wrench to the female fitting of the IP hose. Turn the fitting counterclockwise to loosen and remove the hose from the second stage.
2. Connect the intermediate pressure test gauge to the female fitting of the IP hose, and tighten the hose fitting by hand until finger tight.
3. While holding the IP test gauge positioned facing away from you, pressurize the system by slowly turning the H.A.B.D. valve to the "ON" position. Check the H.A.B.D. pressure gauge assembly once again to ensure that it indicates the cylinder is filled with at least 2,500 psi.
4. Note the intermediate (over-bottom) pressure indicated by the test gauge, and briefly open and shut the bleed valve of the test gauge to ensure that lockup is achieved without "creeping" or fluctuating back and forth.
5. If the intermediate pressure "creeps" up or otherwise fluctuates after cycling the regulator, wait for it to stabilize (if possible) before noting the final intermediate pressure.



**NOTE:** Correct intermediate pressure for the H.A.B.D. is  $140 \pm 5$  psi, with an inlet pressure between 2,500 - 3,000 psi.

6. Partially open the bleed valve of the test gauge to empty the H.A.B.D. cylinder very slowly. DO NOT fully open the test gauge bleed valve to empty the cylinder, as this may cause condensation of moisture to form inside the first stage and hose, as well as the cylinder itself. If the cylinder of valve becomes cold to the touch while performing this step, the air has been relieved too rapidly.



**WARNING:** Failure to completely empty the H.A.B.D. of air prior to performing any disassembly may cause the sudden separation of components or ejection of parts, and may result in serious personal injury.

## Disassembly Procedures



**NOTE:** Before performing any disassembly, refer to the schematic drawing, which references all mandatory replacement parts. These parts should be replaced with new, and must not be reused under any circumstances - regardless of the age of the regulator or how much use it has received since it was last serviced.



**CAUTION:** Use only a plastic or brass O-ring removal tool (PN 944022) when removing O-rings to prevent damage to the sealing surface. Even a small scratch across an O-ring sealing surface could result in leakage. Once an O-ring sealing surface has been damaged, the part must be replaced with new. DO NOT use a dental pick, or any other steel instrument.

## FIRST STAGE DISASSEMBLY

1. Apply an 11/16" open-end wrench to the flats of the pressure gauge assembly (14), and turn the gauge counterclockwise to loosen and remove from the first stage. Remove and discard the O-ring (13), and set the pressure gauge assembly aside.
  2. Apply a 1/2" open-end wrench to the safety plug (11c), and turn counterclockwise to loosen and remove. Discard the safety plug, and do not attempt to reuse.
  3. Check to ensure that the H.A.B.D. valve is closed to the "OFF" position. While holding a shop rag over the first stage to cover the open HP port of the safety plug, direct low pressure air (120-140 psi) through the open HP port to dislodge the safety disc (11b) and gasket (11a) of the safety burst disc assembly (11). (See Figure 4). Remove the shop rag to allow the safety disc and gasket to fall out of the first stage body. Discard these items and do not reuse.
- 3a. Alternate method:** Pierce the safety disc with the pointed o-ring tool. Remove disc, and discard gasket. Use caution not to damage the seating surface.

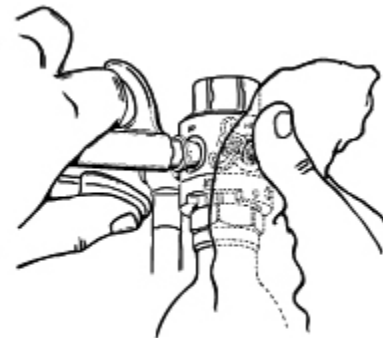

Fig. 4 - Burst disc removal

4. Apply external circlip pliers (PN 111100) to the retaining ring (20) which holds the IP hose (19) in place. Spread the retaining ring and remove from the IP port swivel (17). Discard the retaining ring and do not attempt to reuse.
5. Firmly grasp the banjo fitting of the IP hose and pull it straight off the port swivel. Set the hose and second stage aside.

6. Apply either a 5/16" blade screwdriver (Revision A) or a 5/32" hex key (Revision B) to the port swivel, and turn counterclockwise to loosen and remove. Remove and discard all three O-rings (16 & 18).

**NOTE:** If the port swivel is a Rev. A part (PN 100612), it is important to discard it and install the SRU40A/P retrofit kit (PN 100699), which includes a Rev. B port swivel (PN 102812). (See Figure 5).

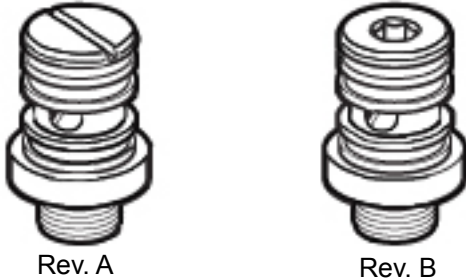

Figure 5 - Rev. A & Rev. B identification

7. Apply a 1/16" hex key to the set screw (12) which holds the indicator ring (15) in place. Turn the screw counterclockwise to loosen until the indicator ring can turn freely (see Figure 6).



Figure 6 - Loosening indicator ring

8. While holding the cylinder secure, turn the first stage assembly counterclockwise by hand to loosen and remove from the cylinder adapter. Lift straight off to remove, using caution to avoid damaging the high pressure seat of the valve body.
9. Gently pull the indicator ring off the stem of the valve assembly. Remove the set screw, and set both items aside.
10. Install a vise mounting tool (PN 100395) or a discharged CO<sub>2</sub> cartridge (PN 13220) connected to a HP port adapter (PN 102085) into the larger HP port of the first stage body. Ensure it is fully seated.

**CAUTION:** DO NOT use a CO<sub>2</sub> cartridge which may have been discharged. Doing so may cause the cartridge to rupture, resulting in serious personal injury.

11. Secure the vise mounting tool in a vise, so that the low pressure side of the first stage faces straight up (see Figure 7).

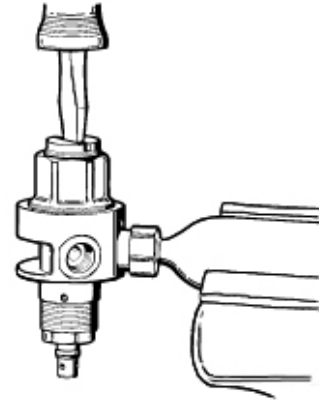

Figure 7 - Adjustment screw removal

12. Apply a 5/16" blade screwdriver to the adjustment screw (1), and turn counterclockwise to loosen and remove from the spring retainer (2). Set the adjustment screw aside.
13. Lift out the washer (3) and the main spring (4). Examine the main spring with the use of a magnifier, checking closely for any signs of pitting, rusting, or other corrosion which permeates the surface of the metal. If permanent corrosion is found, discard the spring and do not attempt to reuse.

**CAUTION:** If permanent corrosion is found, discard the spring and replace with new. DO NOT attempt to reuse.

14. Apply a 1" open-end wrench to the spring retainer, and turn the spring retainer counterclockwise to loosen and remove from the first stage body (10). Inspect the spring retainer to check for any signs of oxidation or corrosion, such as pitting, or thread damage. If any corrosion or damage is found, replace with new and do not reuse.
15. Lift the spring pad (5) out of the first stage and set it aside. Remove the thrust washer (6) and discard.
16. Direct a short burst of low pressure (50 psi) air through the open IP port to dislodge the diaphragm (7) from the first stage body (see Figure 8). Lift out the diaphragm and discard. If LP air is not available, DO NOT attempt to pry out the diaphragm. Please use the alternate method, described after Step 22.

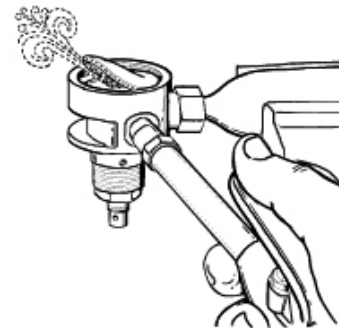

Figure 8 - Removal of diaphragm

**CAUTION:** DO NOT attempt to pry the diaphragm out of the first stage with a metal instrument. Doing so will permanently damage the seating shoulder in the first stage, requiring replacement of the body.

If using the alternate method, please proceed to Step 18.

17. Loosen the vise to remove the vise mounting tool and first stage. Turn the first stage over to allow the pin support (8) and pin (9) to drop out, and set the pin support aside.

17a. Closely examine the head of the pin to identify whether it is a Revision A or Revision B part (see Figure 9).

**NOTE:** If the pin is a Rev. A part (PN 105323), it is important to discard it and install the SRU40A/P retrofit kit (PN 100699), which includes a Rev. B pin (PN 1028-23).



Rev. A Rev. B  
Figure 9 - Rev. A & Rev. B Identification

18. Secure the vise mounting tool in the vise once again, so that the high pressure valve body (28) faces straight up.

19. Apply a 3/4" open-end wrench over the flat hex surface of the valve body, just above the threaded portion of the first stage body. Slowly turn the wrench counterclockwise to loosen and remove the valve body from the first stage body, being careful to prevent the sudden ejection of internal parts beneath the valve body which are under spring pressure (see Figure 10).

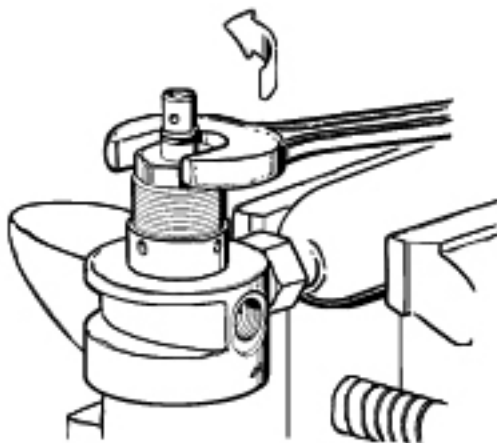

Figure 10 - Removal of the valve body

20. Remove the O-ring (27) from the male threads, and the O-ring (30) and backup ring (29) from the stem of the valve body. Discard these items and do not reuse.

21. Closely examine the seat material inside the end of the valve body stem to check for any excessive wear or damage, such as a deep circular indentation in its center. If the seat material exhibits any signs of excessive wear or damage, or if the valve exhibited leakage during the initial inspection, discard the valve body and do not reuse.

22. Loosen the vise to remove the vise mounting tool and first stage. Turn the first stage over to allow the spring (26), spring block (25), seat spring (22), and high pressure seat (21), to drop out. Discard the high pressure seat and do not reuse. Allow the pin to fall out.

22a. **Alternative Method:** Using the seat extractor (PN 109437), insert it in the body carefully, so not to damage the HP crown, and push the diaphragm out. Review Step 17a and confirm the pin is correct.

23. Closely examine both springs to check for any signs of corrosion that may have resulted from moisture entering the first stage. If corrosion is found, discard and do not reuse.

24. Carefully remove the O-ring (23) and backup ring (24) from inside the balancing chamber of the spring block, using a brass or plastic O-ring removal tool to prevent any damage to the internal sealing surface of the spring block.

25. With the use of a magnifier, closely examine the sealing surface inside the balancing chamber of the spring block to check for any signs of permanent corrosion, scoring, or other damage. If found, discard the spring block and do not reuse.

**CAUTION:** The slightest scratch or scar across the sealing surface inside the spring block may cause leakage, and could prevent the regulator from achieving a stable lock-up of intermediate pressure.

26. With the use of a magnifier, closely inspect the seating surface of the orifice crown inside the first stage body, checking to ensure that it is free of any signs of damage or corrosion.

**NOTE:** Minor blemishes on the crown sealing surface that are caused by slight corrosion or normal wear may be removed with the use of the Crown Polishing Tool (PN 105997). Scratches, nicks, or severe corrosion cannot be removed, however, and will require the replacement of the first stage body.

## CYLINDER ADAPTER DISASSEMBLY

1. Inspect the indicator pin (31) to ensure that it is perfectly straight, and is securely seated inside the cylinder adapter. If the pin is found to be bent or otherwise damaged, remove it with a pair of pliers by twisting slightly and replace with a new pin. Tap the new pin in with a plastic face hammer until it bottoms out.
4. Mate both pins of the Micra retaining ring tool (PN 100188) securely into two opposite slots of the retaining ring (2). Turn the tool counterclockwise to loosen and remove the retaining ring, together with the purge cover (3) and demand diaphragm (4). (See Figure 12).

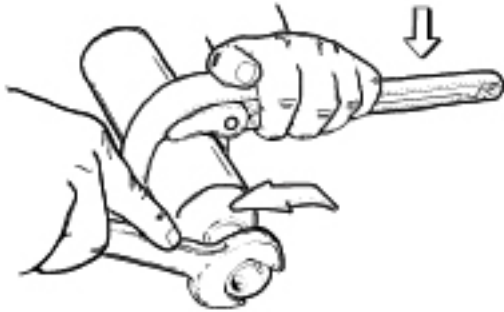

Figure 11 - Removal of cylinder adapter

2. Place the bottle in a bottle vise (PN 100397), vise insert (100398), or place a cloth or rubber strap wrench onto the cylinder (34) to hold it secure. (see Figure 11).
3. While holding the cylinder secure with the strap wrench, apply a 1 1/8" open-end wrench to the adapter (32), and turn counterclockwise to loosen and remove the adapter from the cylinder. Remove and discard the O-ring (33).



Figure 12 - Remove retaining ring

5. Separate the retaining ring, purge cover, and diaphragm, and inspect each of these items closely to ensure that they are perfectly round and free of any tears, corrosion, or other damage. If damage or deterioration is found, discard the item(s) and do not reuse.



**NOTE:** Newer versions of the purge cover do not feature the word "Micra." If no damage is found, the old purge covers may still be used.

## SECOND STAGE DISASSEMBLY (Left Hand Model)



**NOTE:** If the second stage is a right hand model, please refer to the disassembly procedure on page 19.

1. While holding the hex nut (27) of the second stage secure with a 13/16" open-end wrench, apply an 11/16" open-end wrench to the female fitting of the IP hose. Turn the fitting counterclockwise to loosen and remove the hose from the second stage. Remove the O-ring (28) from the hose and discard.
2. Remove the mouthpiece cover (18), if present, and carefully snip the plastic mouthpiece clamp (17) to remove the mouthpiece (19) from the box bottom (22). Inspect the mouthpiece to ensure it is free of any tears or cuts that may cause leakage of water into the second stage or other discomfort. Discard the mouthpiece or set it aside to be reused, depending on its condition.
3. Turn the purge guard (1) counterclockwise by hand to loosen and remove from the second stage box bottom (22).
6. Apply a 13/16" open-end wrench to the hex nut and turn it counterclockwise to loosen and remove.
7. Apply a 5/32" hex key to the cap plug (9) and turn it counterclockwise to loosen and remove. Remove the O-ring (10) from either the cap plug or the box bottom, and discard.
8. Apply a 1/8" blade screwdriver to the slotted head of the black adjustment screw (11) and turn it counterclockwise to loosen and remove. Remove the small, red washer (12) from the stem of the adjustment screw. Inspect these items for any signs of damage. If found, discard the damaged part and do not reuse.
9. Remove the poppet spring (13), and examine it closely through a magnifier. Discard if it is found to be damaged or corroded.
10. Before proceeding, stand the lever (5) up and out of the box bottom, and ensure that it is kept standing while performing the following step.



**CAUTION:** Failure to stand the lever up before attempting to move the valve body may result in permanent damage to the box bottom.

11. While holding the box bottom secure, press the male threaded inlet side of the valve body (23) into the box bottom until it stops, exposing the recessed head of the lever retaining pin (6). (See Figure 13). Turn the box bottom over to drop out the pin, and then pull the lever straight down and out of the valve body to remove. Inspect the lever and pin for any signs of bending, distortion, or excessive wear of the plating. If any of these conditions are found, discard and do not reuse.

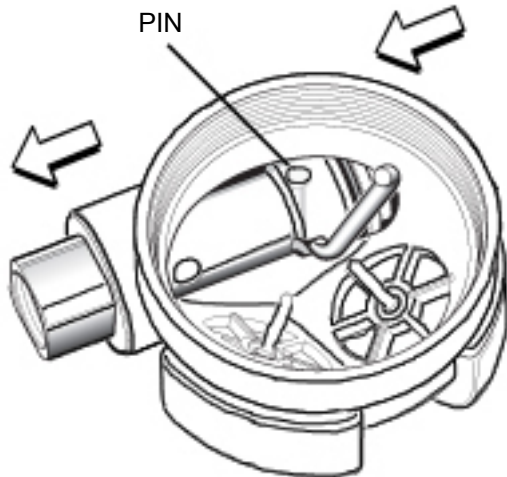

Figure 13 - Removal of lever

12. Turn the box bottom so that the squared end of the valve body faces downward, allowing the poppet (14) which contains the LP seat (15) to drop out. Lightly stick the center of the LP seat with a plastic or brass O-ring tool and lift the seat out, being very careful to avoid damaging the poppet. Discard the seat, and inspect the poppet for any nicks, scratches, or wear of the lever groove. The through-hole beneath the LP seat cavity should be clear and free of any obstructions. Discard the poppet or set it aside to be reused, depending on its condition.
13. While holding the box bottom secure, press against the squared side of the valve body to slide it back out. Grasp the valve body by the male threaded inlet and pull it completely out of the box bottom. Remove and discard the valve body O-ring (24), and set the box bottom aside.
14. While holding the valve body secure, apply a medium blade screwdriver to the slotted head of the crown (25), and turn the crown counterclockwise until its threads have completely disengaged from the valve body.

**NOTE:** Because the crown is O-ring sealed, it will not freely exit the valve body after it has been disengaged. The following step must be performed correctly in order to remove the crown without damaging its delicate sealing surface.

15. When the crown threads have been disengaged from the valve body, carefully insert the pin of the seat extraction tool (PN 109436) through the squared end of the valve body and through the opening in the center of the crown. Gently press the crown out (see Figure 14). Remove and discard the O-ring (26).

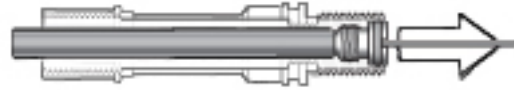

Figure 14 - Removal of crown

16. Closely examine the crown with the use of a magnifier, checking for any scoring, nicks, or other damage to the sealing surface. If damage is found, discard the crown, and do not attempt to reuse. If it is in reusable condition, set it aside on a soft surface to prevent damage to the sealing surface.
17. Stand the box bottom upside down with the mouthpiece boss facing forward so that the circlip (16) which holds the anti-venturi vane (20) secure is clearly visible. If necessary, gently turn the circlip with a small probe until both ends are facing toward the open side of the box bottom.

**NOTE:** To prevent the circlip from becoming lost in the process of removal, place a shop rag over the mouthpiece boss of the box bottom before performing the following step.

18. While holding the box bottom secure, place the tines of the Micra pre-adjustment tool (PN 100168) - or two medium blade screwdrivers if this specialty tool is not available - squarely against the ends of the circlip (see Figure 15). Gently press the circlip off the anti-venturi vane, and set it aside.

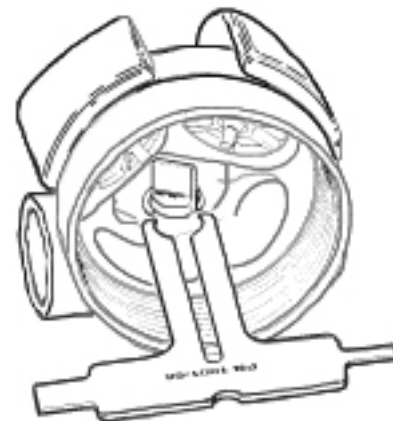

Figure 15 - Removal of anti-venturi vane

19. Pull the anti-venturi vane straight up and out of the mouthpiece boss of the box bottom. Remove and discard the O-ring (21), and set the vane aside.

20. Place a medium blade screwdriver approximately 1/2" inside the top corner of the exhaust cover (8), and press the exhaust cover between thumb and screwdriver (see Figure 16). While holding the box bottom horizontal and secure, sharply pull the exhaust cover out and away from the box bottom only until that corner of the exhaust cover is disengaged.



Figure 16 - Removal of exhaust cover - Step 1

21. Turn the box bottom vertical and press the disengaged side of the exhaust cover up from below, rotating it over the box bottom until the opposite side disengages (see Figure 17).



Figure 17 - Removal of exhaust cover - Step 2

22. Remove and discard the two exhaust valve diaphragms (7).
23. Closely examine the exhaust valves inside the box bottom, and count the number of spokes in each valve to identify whether the box bottom is a Revision A part (three spokes) or Revision B (six spokes). (See Figure 18).

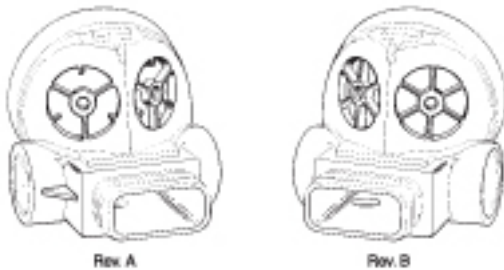

Figure 18 - Rev. A & Rev. B Identification



**NOTE:** If the box bottom is a Revision A part (PN 100644), it is important to discard it and install the SRU40A/P retrofit kit (PN 100699), which includes a Revision B box bottom (PN 102844).

This concludes the disassembly of all H.A.B.D. components. Refer directly to Procedure A and Table A, titled **Cleaning & Lubrication**, before proceeding to the Reassembly Procedures.

## SECOND STAGE DISASSEMBLY (Right Hand Model)

1. While holding the hex nut (27) of the second stage secure with a 3/4" open-end wrench, apply an 11/16" open-end wrench to the female fitting of the IP hose (19). Turn the fitting counterclockwise to loosen and remove the hose from the second stage. Remove the O-ring (28) from the hose and discard.
2. Remove the mouthpiece cover (18), if present, and carefully snip the plastic mouthpiece clamp (17) to remove the mouthpiece (19) from the box bottom (22). Inspect the mouthpiece to ensure it is free of any tears or cuts that may cause leakage of water into the second stage or other discomfort. Discard the mouthpiece or set it aside to be reused, depending on its condition.
3. Turn the purge guard (1) counterclockwise by hand to loosen and remove from the second stage box bottom (22).
4. Mate both pins of the Micra retaining ring tool (PN 100188) securely into two opposite slots of the retaining ring (2). Turn the tool counterclockwise to loosen and remove the retaining ring, together with the purge cover (3) and demand diaphragm (4). (See Figure 19).



Figure 19 - Removal of retaining ring

5. Separate the retaining ring, purge cover, and diaphragm, and inspect each of the items closely to ensure that they are perfectly round and free of any tears, corrosion, or other damage. If damage or deterioration is found, discard the item(s) and do not reuse.
6. Apply a 3/4" open-end wrench to the hex nut and turn it counterclockwise to loosen and remove.
7. Apply the blade side of the retaining ring tool to the cap plug (9) and turn it counterclockwise to loosen and remove (see Figure 20). Remove the O-ring (10) from either the cap plug or the box bottom, and discard.



Figure 20 - Removal of cap plug

8. Apply a 1/8" blade screwdriver to the slotted head of the white adjustment screw (11) and turn it counterclockwise to loosen and remove. Remove the small red washer (12) from the stem of the adjustment screw. Inspect these items for any signs of damage. If found, discard the damaged part and do not reuse.
9. Remove the poppet spring (13), and examine it closely through a magnifier. Discard if it is found to be damaged or corroded.
10. Before proceeding, stand the lever (5) up and out of the box bottom, and ensure that it is kept standing while performing the following step.



**CAUTION:** Failure to stand the lever up before attempting to move the valve body may result in permanent damage to the box bottom.

11. While holding the box bottom secure, press against the male threaded inlet side of the valve body (23) until the head of the lever retaining pin (6) is visible (see Figure 21). Turn the box bottom over to drop out the pin, and then remove the lever. Inspect the lever and pin for any signs of bending, distortion, or excessive wear of the plating. If any of these conditions are found, discard and do not attempt to reuse.

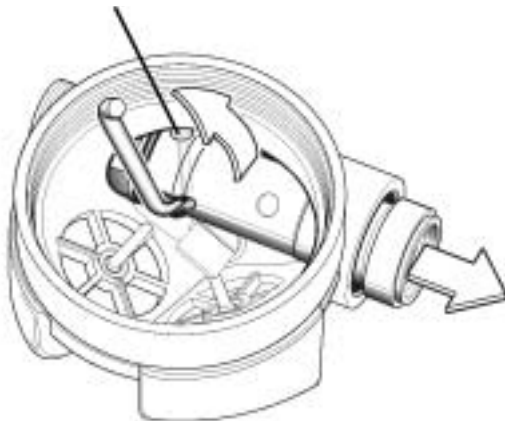

Figure 21 - Removal of lever



**NOTE:** If corrosion or salt crystals are present, it may be necessary to press out the small end of the pin by inserting the pin of the extraction tool (PN 109436) through the mouthpiece boss and the opposite side of the valve body.

12. Continue pressing the valve body until it can be pulled out and removed from the opposite side of the box bottom. Tilt the female threaded end of the valve body down to drop out the poppet (14) that contains the LP seat (15). Remove and discard the valve body O-ring (24).
13. Lightly stick the center of the LP seat with a plastic or brass O-ring tool and lift the seat out, being very careful to avoid damaging the poppet. Discard the seat, and inspect the poppet for any nicks, scratches, or wear of the lever groove. The through-hole beneath the LP seat cavity should be clear and free of any obstructions. Discard the poppet or set it aside to be reused, depending on its condition.
14. While holding the valve body secure, apply a medium blade screwdriver to the slotted head of the crown (25), and turn the crown counterclockwise until its threads have completely disengaged from the valve body.



**NOTE:** Because the crown is O-ring sealed, it will not freely exit the valve body after it has been disengaged. The following step must be performed correctly in order to remove the crown without damaging its delicate sealing surface.

15. When the crown has been disengaged from the valve body, carefully insert the pin of the seat extraction tool (PN 109436) through the opposite end of the valve body and through the opening in the center of the crown. Gently press the crown out (see Figure 22). Remove and discard the O-ring (26).

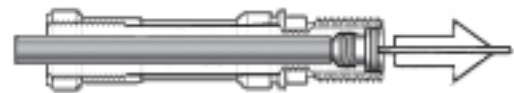

Figure 22 - Removal of crown

16. Closely examine the crown with the use of a magnifier, checking for any scoring, nicks, or other damage to the sealing surface. If damage is found, discard the crown, and do not attempt to reuse. If it is in reusable condition, set it aside on a soft surface to prevent damage to the sealing surface.
17. Stand the box bottom upside down with the mouthpiece boss facing forward so that the circlip (16) which holds the anti-venturi vane (20) secure is clearly visible. If necessary, gently turn the circlip with a small probe until both ends are facing toward the open side of the box bottom.

**NOTE:** To prevent the circlip from becoming lost in the process of removal, place a shop rag over the mouthpiece boss of the box bottom before performing the following step.

18. While holding the box bottom secure, place the tines of the Micra pre-adjustment tool (PN 100168) - or two medium blade screwdrivers if this specialty tool is not available - squarely against the ends of the circlip (see Figure 23). Gently press the circlip off the anti-venturi vane, and set it aside.

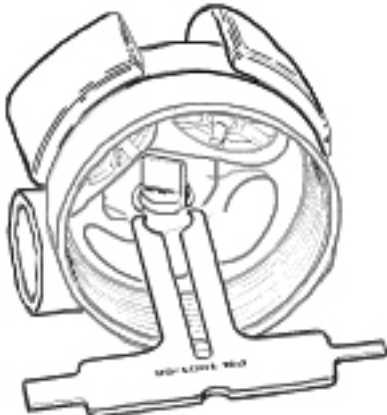

Figure 23 - Removal of anti-venturi vane

19. Pull the anti-venturi vane straight up and out of the mouthpiece boss of the box bottom. Remove and discard the O-ring (21), and set it aside.
20. Place a medium blade screwdriver approximately 1/2" inside the top corner of the exhaust corner (8), and press the exhaust cover between thumb and screwdriver (see Figure 24). While holding the box bottom horizontal and secure, sharply pull the exhaust cover out and away from the box bottom only until that corner of the exhaust cover is disengaged.



Figure 24 - Removal of exhaust cover - Step 1

21. Turn the box bottom vertical and press the disengaged side of the exhaust cover up from below, rotating it over the box bottom until the opposite side disengages. (see Figure 25).



Figure 25 - Removal of exhaust cover - Step 2

22. Remove and discard the two exhaust valve diaphragms (7).
23. Closely examine the exhaust valves inside the box bottom, and count the number of spokes in each valve to identify whether the box bottom is a Revision A part (three spokes) or Revision B (six spokes). (See Figure 26).

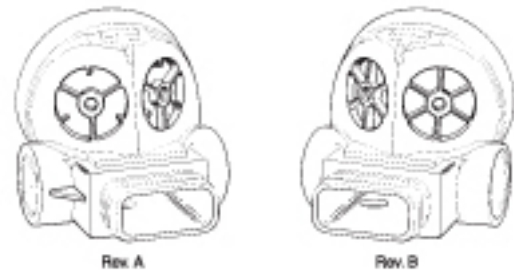



Figure 26 - Rev. A & Rev. B Identification

**NOTE:** If the box bottom is a Revision A part (PN 100644), it is important to discard it and install the SRU40A/P retrofit kit (PN 100699), which includes a Revision B box bottom (PN 102844).

This concludes the disassembly of all H.A.B.D. components. Refer directly to **Procedure A - Cleaning & Lubrication**, and **Table A - Recommended Lubricants & Cleaners**, before proceeding to the Reassembly Procedures.

## Reassembly Procedures

 **NOTE:** Before reassembling, it is important to inspect all parts, both new and those that are being reused, to ensure that every part is perfectly clean and free of any dust, corrosion, or blemishes. Check all O-rings to ensure they are clean and supple before dressing with Christo-Lube®.

 **WARNING:** Use only genuine Aqua Lung® parts provided in the HABD overhaul parts kits. DO NOT attempt to substitute an Aqua Lung® part with another manufacturer's, regardless of any similarity in shape or size. Doing so may render the product unsafe, and could result in serious injury or death.

### CYLINDER ADAPTER REASSEMBLY

 **CAUTION:** Before proceeding, it is necessary to perform a visual inspection of the cylinder according to Compressed Gas Association (CGA) standards, with the use of a visual inspection light. If the condition of the cylinder does not meet the required standards, it must either be serviced or replaced with new before it can be assembled and filled.

1. Lightly lubricate the O-ring (33) and place onto the threaded male stem of the cylinder adapter (32).
2. Lightly lubricate the first two male threads of the adapter with Christo-Lube®. Thread the adapter clockwise into the cylinder (34) until handtight.
3. Place bottle in a bottle vise (PN 100397), vise insert (PN 100398), or place a strap wrench onto the cylinder to hold it secure while it is turned in a counterclockwise direction. (See Figure 27).

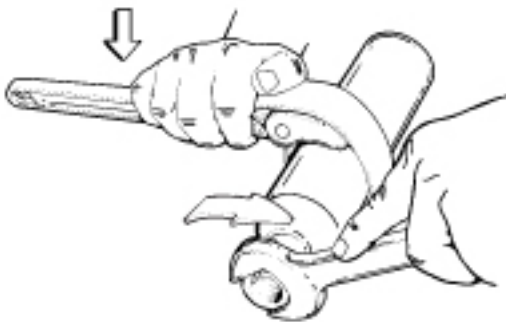



Figure 27 - Installation of cylinder adapter

4. While holding the cylinder secure, apply a torque wrench with a 1 1/8" crow-foot or socket to tighten the cylinder adapter to a torque measurement or **25 ± 2 ft-lbs.**
5. Lightly lubricate the female threads of the cylinder adapter with food grade (U.S.D.A. approved) anti-seize lubricant.

 **CAUTION:** Be careful to prevent any O-rings from coming in contact with the anti-seize lubricant, which can cause premature deterioration of nitrile buna and EPDM materials.

### FIRST STAGE REASSEMBLY

1. Install the O-ring (13) onto the pressure gauge (14), at the base of the male threads. Set the pressure gauge assembly aside.
2. Install the backup ring (24), and then O-ring (23), into the chamber of the spring block (25). Set this assembly aside.
3. While holding the high pressure seat (21) by its stem, gently lower it into the inlet boss of the first stage body until it rests flat on top of the orifice crown.
4. Place the spring (22) over the stem of the high pressure seat.
5. Insert the open end of the spring block (25) into the center of the high pressure seat spring, and then place the smaller spring (26) directly over the large end of the spring block.
6. Install the backup ring (29) onto the stem of the valve body with the concave surface facing up, followed by the O-ring (30), which should fit flush against the concave surface (see Figure 28). Then, install the O-ring (27) onto the opposite side of the valve body, at the base of the threads.

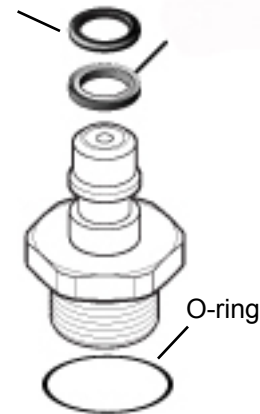

 **CAUTION:** It is important to ensure that the backup ring is installed with the concave surface facing toward the O-ring. The O-ring may otherwise extrude and become damaged.

7. Lightly lubricate the male threaded end of the valve body with Christo-Lube®, and carefully mate it into the inlet boss of the first stage body. Press the valve body downward while turning clockwise to engage the threads, and tighten it until finger snug.

8. While holding the first stage with the low pressure side facing up, carefully insert the small end of the pin (9) into the center hole of the body until only the larger end is protruding.

 **NOTE:** If the pin was identified as a Revision A part during disassembly, it is important to replace it with the Revision B pin that is provided in the SRU-40A/P retrofit kit.

9. Install the pin support (8) over the large end of the pin.
10. Lay the diaphragm (7) inside the body, and gently tap it down until it is evenly seated at the base of the female threads.
11. Lay the thrust washer (6) inside the body, and press it firmly down until it is seated evenly over the diaphragm.
12. Lay the spring pad (5) in the center of the diaphragm with the mating tab facing up, lubricate the threads of the spring retainer (2), and thread the spring retainer (2) clockwise into the body by hand until snug.
13. Install a vise mounting tool (PN 100395) or a discharged CO2 cartridge (PN 13220) connected to a HP port adapter (PN 102085) into the larger HP port of the first stage body.
14. Secure the vise mounting tool in a vise, with the inlet boss of the first stage body facing straight up. Apply a torque wrench with 3/4" crow-foot or deep socket to tighten the valve body to a torque measurement of **60 ± 5 inch-lbs.** (See Figure 29).

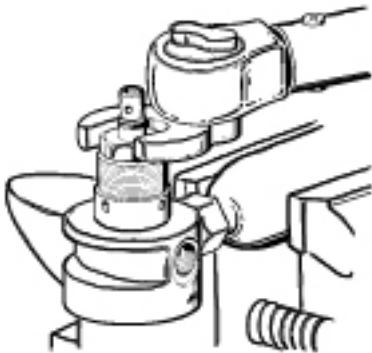

Figure 29 - Torque measurement of valve body

15. Re-secure the first stage inside the vise with the spring retainer facing straight up. Apply a torque wrench with 1" crow-foot or socket to tighten the spring retainer to a torque measurement of **25 ± 2 ft-lbs.** (See Figure 30).

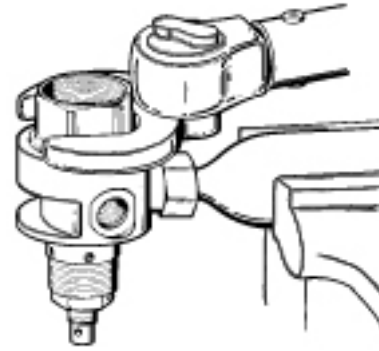

Figure 30 - Torque measurement of spring retainer

16. After checking to ensure that the spring pad is positioned over the center of the diaphragm, install the main spring (4) into the spring retainer, followed by the washer (3) on top of the spring.
17. Lightly lubricate the lower threads with Christo-Lube® and mate the adjustment screw (1) over the spring and washer, and turn it clockwise to engage the threads. Apply a 5/16" blade screwdriver to turn the adjustment screw further until it is flush with the top of the spring retainer (see Figure 31).

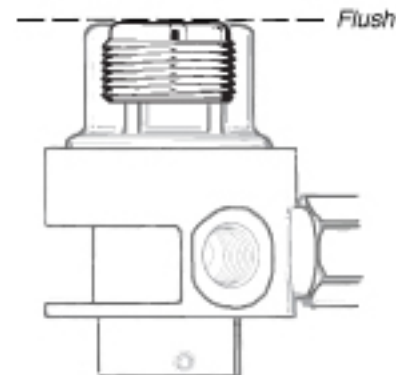

Figure 31 - Adjustment screw preliminary setting

18. Reposition the first stage horizontal inside the vise, and place a new gasket (11a) inside the smaller high pressure port (marked "HP"), followed by a new burst disc (11b) with the red side facing out. Use a non-metallic probe to seat these items evenly at the base of the female threads.
19. Mate a new safety plug (11c) into the port, and thread clockwise by hand until snug. Apply a torque wrench with 1/2" hex socket to tighten the safety plug to a torque measurement of **90 ± 5 inch-lbs.**
20. **STOP.** Allow a waiting period of at least 12 hours before proceeding further, and then **repeat steps 15 & 19.**



**CAUTION:** It is important to allow a waiting period of at least twelve (12) hours before proceeding further, and then re-torque the spring retainer (2) and safety plug (11c) according to steps 15 & 19. These parts may otherwise lose their original torque values after the seals have become slightly compressed, which could result in leakage of air.

21. Install the O-ring (16) onto the port swivel (17), at the base of the male threads. Install the other two O-rings (18) into the two grooves on opposite sides of the orifice of the port swivel.
22. Resecure the first stage horizontally inside the vise with the IP port facing up. Mate the port swivel into the IP port, and turn clockwise to engage the threads. Apply a torque wrench with 5/32" hex key socket to tighten to a torque measurement of **60 ± 3 inch-lbs.**



**NOTE:** If the port swivel was identified as a Revision A part during disassembly, it is important to replace it with the Revision B port swivel that is provided in the SRU-40A/P retrofit kit.

23. Loosen the vise to remove the first stage, and remove the vise mounting tool from the high pressure port.
24. Mate the stem of the valve assembly through the flat side of the indicator ring (15), so that the indicator ring is flush against the first stage body and the "OFF" aperture is facing down.
25. While holding the first stage and indicator ring together, mate the first stage / valve assembly into the cylinder adapter. Be careful to avoid contact with the anti-sieze lubricant. While holding the cylinder secure, turn the first stage clockwise by hand, and stop when resistance is felt.
26. Turn the indicator ring clockwise to align the set screw hole with the female threaded hole of the valve assembly which is to the immediate right of the indicator pin. (See Figure 32).

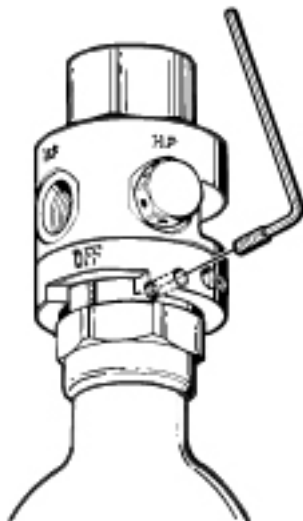

Figure 32 - Indicator ring alignment

27. Mate the male end of the set screw (12) through the indicator ring against the hole of the valve assembly. Apply a 1/16" hex key to tighten the set screw clockwise until snug.
28. While holding the cylinder secure, turn the first stage/ valve assembly further clockwise until lightly snug. The indicator pin should be inside the aperture cutout of the indicator ring marked "OFF." Resistance should be felt before the indicator pin reaches the far right side of the "OFF" aperture. If not, reposition the indication ring. Be careful to avoid overtightening.
29. Place the banjo fitting of the hose directly over the port swivel, and firmly press straight down until it is seated at the base.
30. Closely examine the retaining ring (20) to identify that it is flat on one side and slightly rounded on the other. Apply external circlip pliers to install the retaining ring onto the port swivel with its flat side facing out, and check to ensure that it is snugly fastened inside the groove.



**CAUTION:** Be careful to avoid stretching the retaining ring while installing, and do not use a retaining ring that has become stretched.

## SECOND STAGE REASSEMBLY (Left Hand and Right Hand Models)

1. Install the O-ring (28) into the second stage fitting of the IP hose, and set the first stage / cylinder assembly aside.
2. Install the O-ring (21) onto the anti-venturi vane (20).
3. Mate the stem of the anti-venturi vane into its respective hole in the box bottom (22) above the mouthpiece boss, and align the indicator pin in its locked position. When the vane is correctly aligned, press it down and into place so that it is properly seated inside the box bottom (see Figure 33).

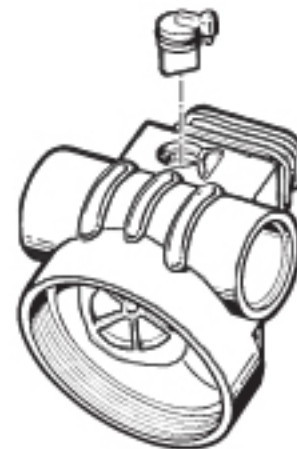

Figure 33 - Anti-venturi vane installation

**NOTE:** If the box bottom was identified as a Revision A part during disassembly, it is important to replace it with Revision B box bottom provided in the SRU-40A/P retrofit kit.

- While holding the anti-venturi vane in place, turn the box bottom upside down with the open side facing away. Lay the circlip (16) inside the mouthpiece boss, with its flat side facing up. Rotate the circlip as needed to position the open end directly behind the stem of the vane.
- Place the tines of the Micra pre-adjustment tool (PN 100168) squarely behind the circlip, and press the circlip evenly onto the groove of the vane stem until it audibly snaps into place (see Figure 34). Examine closely to ensure that the circlip is seated evenly over the stem of the vane, inside the groove.

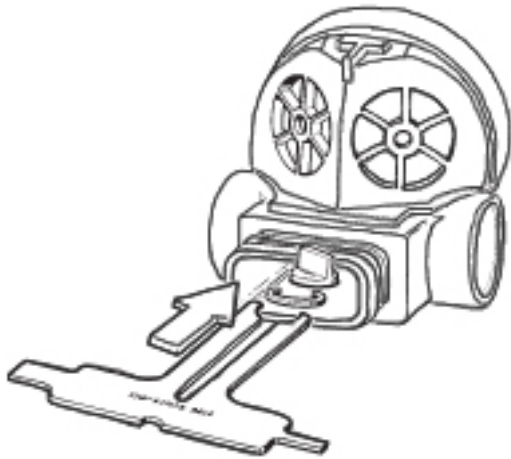

Figure 34 - Circlip installation

**CAUTION:** It is important to ensure that the vane, O-ring, and circlip are correctly installed in order to maintain the watertight integrity of the box bottom assembly. Improper installation may result in flooding of the second stage.

**NOTE:** If a pre-adjustment tool is not available, the circlip can be pressed into place with the use of a medium blade screwdriver while the box bottom is turned upside down. Be careful, however, to avoid damaging the box bottom or vane.

- Install each exhaust valve diaphragm (7) into the box bottom by gently pulling the stem through the hole in the center of the support spokes, until the barb has passed through and is securely seated against the opposite side. Carefully snip off the excess material of each stem with a small pair of scissors, leaving about a 1/4" showing.

## SECOND STAGE REASSEMBLY (Right Hand Model)

**NOTE:** If the second stage is a right hand model, please refer to the reassembly procedure on page 21.

- Install the O-ring (26) onto the crown (25), and carefully insert the threaded end of the crown into the inlet end of the valve body (23). Gently press it in further with the blunt end of the seat extraction tool (PN 109436) until it stops (see Figure 35).

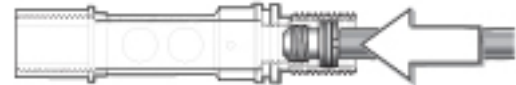

Figure 35 - Crown installation

**NOTE:** Do not attempt to thread the crown into the valve body at this time.

- Lay the LP seat (15) into the cavity on the end of the poppet (14), checking first to ensure that the perfectly smooth side of the seat is facing out, and press the seat firmly into place.
- Position the valve body horizontally, so that the male threaded inlet faces directly to the right and the two outlet ports in the center of the barrel face directly up. Locate the small pin hole that is adjacent to these on the right, in the raised feature on the inlet side of the valve body.
- Examine the length of the poppet to locate the side which contains an elliptical hole centered between two of the ribs. Align the poppet to the left of the squared end of the valve body, with the LP seat facing in, so that the elliptical hole is perfectly in line with the center of the outlet ports and the pin hole in the valve body (see Figure 36).



Figure 36 - Poppet & valve body alignment

- Slide the poppet completely into the valve body, and check to ensure that the alignment has not been disturbed. If necessary, gently rotate the poppet with a blunt probe through the outlet ports of the valve body to correct the alignment.
- Without disturbing the alignment of the poppet inside, stand the valve body vertically with the squared end facing up. While holding it secure in this position, closely examine the four flat surfaces to identify one which is slightly narrower than the others. Compare this feature to the squared opening in the box bottom to determine how these parts are indexed to fit together (see Figure 37).

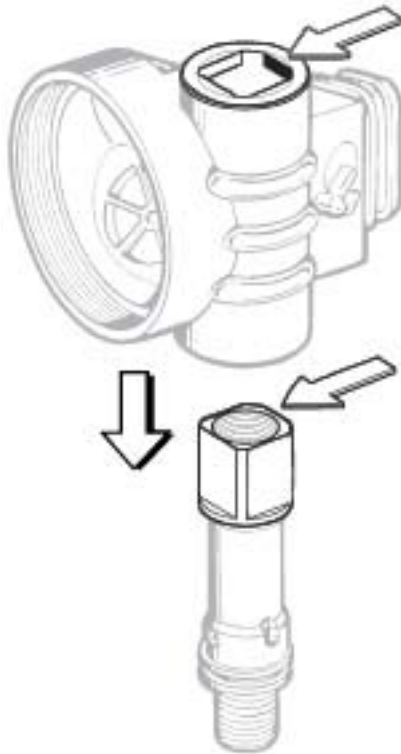

Figure 37 - Valve body & box bottom index



**CAUTION:** Proper alignment is critical to avoid damage to the box bottom.

7. Continue to hold the valve body secure, standing vertical. Guide the round inlet opening of the box bottom down over the valve body until the indexed features of both parts can be visually aligned with each other. Press the box bottom completely down over the valve body, until the squared end of the valve body is protruding out of the opening.
8. Insert the notched end of the lever (5) into the elliptical hole of the valve body that is just below the recessed pin hole. Stand the lever up vertically, straight out of the box bottom, and hold it securely in place to prevent it from falling out.



**NOTE:** If the lever cannot be easily inserted into the valve body, the poppet is not correctly aligned inside. Remove the valve body to disassemble and repeat steps 10-12 to realign the poppet as needed before proceeding.

9. While holding the lever securely in place and standing straight up, insert the retaining pin (6) into the recessed hole of the valve body, past the notched section of the lever, and through the poppet inside. Gently wiggle the lever back and forth if necessary to cause the pin to seat completely, until the head rests flush inside the recess of the valve body (see Figure 38).



Figure 38 - Installation of lever

10. Press the squared end of the valve body inward, in order to hold the retaining pin in place.
11. Insert the poppet spring (13) into the open end of the valve body, and check to ensure that it seats evenly over the stem of the poppet inside.
12. Install the red washer (12) onto the stem of the black adjustment screw (11). Mate the stem of the adjustment screw through the open end of the valve body and into the center of the spring, and turn it clockwise by hand to engage the threads until it is perfectly flush with the end of the valve body.
13. Apply the small blade of the Micra pre-adjustment tool to turn the adjustment screw clockwise as far as the engagement of the tool will allow (see Figure 39). Or, if the pre-adjustment tool is not available, apply a 1/8" blade screwdriver to turn the adjustment screw clockwise exactly 360° full turns.



Figure 39 - Adjustment screw pre-set adjustment



**NOTE:** If the lever has been properly installed, it will rise slightly as the adjustment screw is turned in to its preliminary setting. If the lever does not rise, check to determine if it is properly installed into the valve body.

14. Apply the large blade of the Micra pre-adjustment tool to turn the crown clockwise as far the engagement of the tool will allow (see Figure 40). Or, if the Micra pre-adjustment tool is not available, apply a medium blade screwdriver to turn the crown clockwise exactly **six** 360° full turns.
15. Press the square end of the valve body into the box bottom so that the inlet end exits the opposite side. While maintaining pressure against the square end, install the O-ring (24) into the groove that is exposed outside the box bottom (see Figure 41).



Figure 41 - Installation of valve body O-ring

**NOTE:** It is important to install the O-ring after the valve body has been installed into the box bottom, in order to avoid cutting or damaging the O-ring while sliding the valve body back and forth during assembly.

16. Thread the hex nut (27) clockwise onto the inlet end of the valve body, and turn by hand until it is finger snug and seated flush against the box bottom.
17. Examine the exhaust cover (8) and the box bottom to identify the locking tabs and slots of each respective part. Press one corner of the exhaust cover onto the box bottom until the mating tab audibly snaps into place. Press the center tab next, followed by the tab of the opposite corner, and check to ensure that all three tabs are securely locked into their slots.
18. Install a mouthpiece (19) onto the box bottom, and lightly fasten a mouthpiece clamp (17) onto the groove of the mouthpiece. Turn the clamp so that the locking tab is aligned with the air inlet of the box bottom, and pull the clamp sufficiently snug. Snip the extra length with a small pair of wire cutters.

**NOTE:** The cap plug (9), O-ring (10), diaphragm (4), purge cover (3), and retaining ring (2) should not be installed until after the final adjustments and testing procedures have been completed.

This concludes the reassembly of all H.A.B.D. components. Refer directly to the section titled, **Final Adjustment & Testing**, on page xx.

## SECOND STAGE REASSEMBLY (Right Hand Model)

1. Install the O-ring (26) onto the crown (25), and carefully insert the threaded end of the crown into the inlet end of the valve body (23). Gently press it in further with the blunt end of the seat extraction tool (PN 109436) until it stops (see Figure 44).

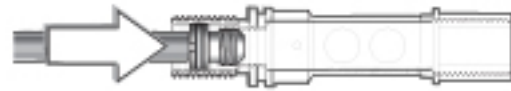

Figure 44 - Crown installation

**NOTE:** Do not attempt to thread the crown into the valve body at this time.

2. Install the O-ring (24) into the groove of the valve body near the threaded inlet.
3. Lay the LP seat (15) into the cavity on the end of the poppet (14), checking first to ensure that the perfectly smooth side of the seat is facing out, and press the seat firmly into place.
4. Position the valve body horizontally, so that the male threaded inlet faces directly to the left and the two outlet ports in the center of the barrel face directly up. Locate the small pin hole that is adjacent to the left of these, between the chamber and the groove.
5. Examine the length of the poppet to locate the side which contains an elliptical hole centered between two of the ribs. Align the poppet to the right of the valve body, with the LP seat facing in, so that the elliptical hole is perfectly in line with the center of the outlet ports and the pin hole in the valve body (see Figure 45).

Inlet end



Figure 45 - Poppet and valve body alignment

6. Slide the poppet completely into the valve body, and check to ensure that the alignment has not been disturbed. If necessary, gently rotate the poppet with a blunt probe through the outlet ports of the valve body to correct the alignment.
7. With the inlet end of the valve body tilted slightly downward to hold the poppet in place, rotate the valve body 180 degrees so that the recessed hole for the lever retaining pin is visible and facing up. While holding the valve body in this position, insert the threaded inlet end into the circular opening of the box bottom. Pass the valve body through until only 2-3 threads protrude outside the opposite side of the box bottom, and the recessed pinhole remains visible.

8. Insert the notched end of the lever (5) into the elliptical hole of the valve body that is just below the recessed pin hole. Stand the lever up vertically, straight out of the box bottom, and hold it securely in place to prevent it from falling out.

**NOTE:** If the lever cannot be easily inserted into the valve body, the poppet is not correctly aligned inside. Remove the valve body to disassemble and repeat steps 11-13 to realign the poppet as needed before proceeding.

9. While holding the lever securely in place and standing straight up, insert the retaining pin (6) into the recessed hole of the valve body, past the notched section of the lever, and through the poppet inside. Gently wiggle the lever back and forth if necessary to cause the pin to seat completely, until the head rests flush inside the recess of the valve body (see Figure 46).



Figure 46 - Installation of lever

**NOTE:** The valve body and box bottom are both indexed with four flat surfaces where their inlet portions mate. In order to maintain the correct orientation of these parts, it is necessary for the retaining pin hole of the valve body to be facing straight up and out of the box bottom, while the elliptical hole for the lever faces towards the exhaust valve.

10. While holding the lever up, gently press the valve body into place until the indexed shoulder is securely seated flush with the surrounding outer surface of the box bottom. If necessary, first use the lever to rotate the valve body slightly in either direction until its indexed feature is properly aligned with the box bottom.

**CAUTION:** Do not apply undue force to press the valve body into place. Doing so may cause the O-ring (24) to bind up and become unseated, which may allow water to leak into the box bottom (see Figure 47). If bind-up occurs, remove the valve body and check to ensure that the O-ring has been dressed with a sufficient amount of lubricant.

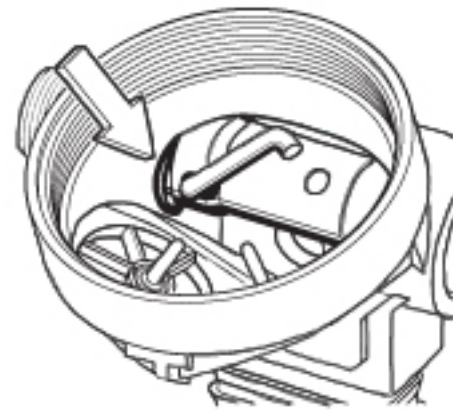

Figure 47 - O-ring bind-up

11. Insert the poppet spring (13) into the open end of the valve body, and check to ensure that it seats evenly over the stem of the poppet outside.
12. Install the red washer (12) onto the stem of the white adjustment screw (11). Mate the stem of the adjustment screw through the open end of the valve body and into the center of the spring, and turn it clockwise by hand to engage the threads until it is perfectly flush with the end of the valve body.
13. Apply the small blade of the Micra pre-adjustment tool to turn the adjustment screw clockwise as far as the engagement of the tool will allow (see Figure 48). Or, if the pre-adjustment tool is not available, apply a 1/8" blade screwdriver to turn the adjustment screw clockwise exactly **eight** 360° full turns.



Figure 48 - Adjustment screw pre-set adjustment

**NOTE:** If the lever has been properly installed, it will rise slightly as the adjustment screw is turned in to its preliminary setting. If the lever does not rise, check to determine if it is properly installed into the valve body.

14. Apply the large blade of the Micra pre-adjustment tool to turn the crown clockwise as far as the engagement of the tool will allow (see Figure 49). Or, if the Micra pre-adjustment tool is not available, apply a medium blade screwdriver to turn the crown clockwise exactly **six** 360° full turns.



Figure 49 - Crown pre-set adjustment

15. Thread the hex nut (27) clockwise onto the inlet end of the valve body with the shoulder facing inward. Turn it by hand until it is finger snug and seated flush against the box bottom.
16. Examine the exhaust cover (8) and the box bottom to identify the locking tabs and slots of each respective part. Press one corner of the exhaust cover onto the box bottom until the mating tab audibly snaps into place. Press the center tab next, followed by the tab of the opposite corner, and check to ensure that all three tabs are securely locked into their slots.
17. Install the mouthpiece (19) onto the box bottom, and lightly fasten a mouthpiece clamp (17) onto the groove of the mouthpiece. Turn the clamp so that the locking tab is aligned with the air inlet of the box bottom, and pull the clamp sufficiently snug. Snip the extra length with a small pair of wire cutters.

 **NOTE:** The cap plug (9), O-ring (10), diaphragm (4), purge cover (3), and retaining ring (2) should not be installed until after the final adjustments and testing procedures have been completed.

This concludes the reassembly of all H.A.B.D. components. Refer directly to the section titled, **Final Adjustment & Testing**, on page 22.

## Final Adjustment & Testing Procedures

### FIRST STAGE ADJUSTMENT



**CAUTION:** Do not proceed unless step 21 of the first stage reassembly procedure has been completed. The spring retainer (2) and safety plug (11c) may otherwise not remain torqued to their correct values, which could lead to a possible airleak situation



**NOTE:** The following procedure is for SCUBA bottle/HABD charging. Follow instructions on the MRS III or local instructions for alternate charging methods.

1. Connect the intermediate pressure test gauge to the female fitting of the IP hose, and tighten the hose fitting onto the gauge by hand until finger snug. Turn the bleed valve knob of the gauge counterclockwise to ensure that it is open.
2. Inspect the nozzle of the SCUBA fill adapter (PN 100655) to ensure the O-ring is present and seated evenly at the base of the threads, and mate the nozzle into the open HP port. Turn clockwise by hand until snug. **DO NOT** apply a wrench or otherwise overtighten the fill adapter into the first stage.
3. Loosen the fill adapter yoke screw as needed to remove the dust cap from the inlet fitting. While supporting the H.A.B.D. with one hand, place the yoke onto the valve of a supply cylinder that is filled with exactly 500 psi. Align the inlet fitting flush against the valve O-ring, and tighten the fill adapter yoke screw clockwise into the small dimple on the backside of the cylinder valve until finger snug (see Figure 50).



Figure 50 - SCUBA fill adapter connection with supply cylinder

4. Check to ensure that the first stage adjustment screw (1) is preset flush with the top of the spring retainer (2) (see Figure 51).

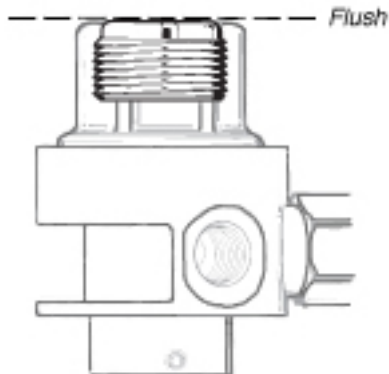

Figure 51 - Adjustment screw preliminary setting



**NOTE:** Do not open the H.A.B.D. valve at this time. This will cause the cylinder to fill with air, and will require that the cylinder is emptied in the event that any problems are detected which require the disassembly of the first stage.

5. Check to ensure that the H.A.B.D. valve is turned to the "OFF" position. While supporting the H.A.B.D. cylinder, proceed to slowly open the valve of the supply cylinder while closely monitoring the IP test gauge to ensure that the intermediate pressure does not rise above 150 psi.



**WARNING:** If the intermediate pressure rises above 150 psi, shut the cylinder valve immediately. Refer to **Table 1 - Troubleshooting**, and remedy as needed before proceeding any further. Failure to shut the cylinder valve before the intermediate pressure exceeds 400 psi will result in damage to the test gauge, and may cause serious personal injury.

6. Proceed to slowly turn the knob of the bleed valve clockwise until it is completely shut while continuously monitoring the test gauge to ensure that the intermediate pressure does not rise above 150 psi.



**NOTE:** If the intermediate pressure continues to rise above 150 psi, immediately reopen the bleed valve of the test gauge and shut the valve of the supply cylinder. Refer directly to **Table 1 - Troubleshooting**, and remedy as needed before proceeding any further.

7. When the intermediate pressure has stabilized before 150 psi, apply a 5/16" blade screwdriver to turn the first stage adjustment screw in small increments of adjustment. Turn the adjustment screw clockwise to raise the intermediate pressure, or counterclockwise to lower it. While turning the adjustment screw, it is important at the same time to also turn the bleed valve of the test gauge briefly open and shut to maintain an accurate reading of the test gauge. Monitor the test gauge while adjusting in this manner until the intermediate pressure locks up at 140 +/- 5 psi.
8. Turn the cylinder valve completely shut, and ensure that the H.A.B.D. valve remains shut to the "OFF" position. Open the bleed valve of the test gauge to depressurize, and loosen the yoke screw of the fill adapter to remove the H.A.B.D. from the supply cylinder. Turn the bleed valve of the test gauge completely shut before proceeding to the next step.
9. Attach the H.A.B.D. to a supply cylinder that is filled with 3,000 psi, via the SCUBA fill adapter.
10. With the H.A.B.D. cylinder held supported, slowly open the supply cylinder valve. At the same time, it is important to continue monitoring the IP test gauge to ensure that the immediate pressure does not rise above 145 psi. If the intermediate pressure rises above 145 psi, immediately reopen the bleed valve of the test gauge and shut the valve of the supply cylinder. Refer directly to **Table 1 - Troubleshooting**, and remedy as needed before proceeding.
11. Repeat the adjustment procedure given above to adjust the H.A.B.D. first stage intermediate pressure to exactly 140 psi. Repeatedly open and shut the bleed valve at least 10 times to ensure that the intermediate pressure locks up consistently and remains stable, with no signs of creeping or fluctuation.



**CAUTION:** Failure to cycle the regulator during adjustment can result in a false reading of the intermediate pressure.

12. Turn the supply cylinder valve completely shut, and check to ensure that the H.A.B.D. valve remains shut to the "OFF" position. Open the bleed valve of the test gauge to depressurize, and remove the test gauge from the IP hose.

## SECOND STAGE ADJUSTMENT

 **NOTE:** Before performing the following procedure, refer to Table 6, titled **Test Bench Specifications - H.A.B.D.**

1. If necessary, connect the H.A.B.D. to a flow test bench, or a cylinder containing 3,000 psi, via the SCUBA fill adapter.
2. Attach the female fitting of the intermediate pressure hose to the In-Line Adjustment Tool (PN 100195) by mating the swivel nut onto the male threaded end of the tool. Turn the swivel nut clockwise by hand until finger snug.

 **NOTE:** It will be necessary to hold the valve body secure throughout this procedure, in order to prevent it from exiting the box bottom.

3. Pull back the knob of the tool to retract the adjusting stem, and mate the female threaded end of the tool onto the second stage inlet fitting. While holding the tool secure, turn the second stage clockwise until lightly snug (see Figure 52).

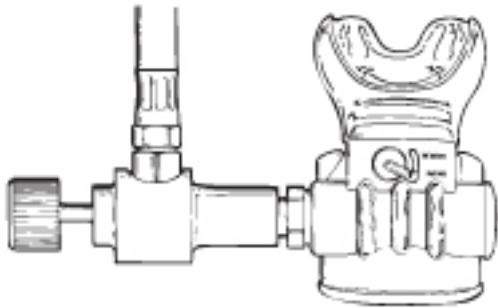



Figure 52 - In-line adjustment tool connection (RH model)

4. With the H.A.B.D. cylinder held supported, slowly open the supply cylinder valve to pressurize the system. Listen to determine whether air is flowing from the second stage.

 **NOTE:** If air flow is detected, it will be necessary to repeat steps 13 & 14 of the second stage reassembly procedure, in order to correctly pre-set the crown and adjustment screw.

5. Place the notched side of the lever height gauge (PN 102868) directly over the rim of the box bottom, and adjust the orifice crown as needed to set the lever height so that the top of the lever is flush with the bottom of the gauge (see Figure 53).



Figure 53 - Lever height setting (RH model)

6. To adjust the orifice crown, press the knob of the adjustment tool inward, and gently turn the knob until it can be felt that the adjustment stem has mated into the slotted head of the orifice. Continue to hold the knob inward to prevent it from being pressed outward by the internal air pressure. Turn the knob of the adjustment tool clockwise in very small increments to lower the lever, or counterclockwise to raise it. When the lever is set perfectly flush with the bottom of the gauge, release the knob of the adjustment tool to ensure that it no longer makes contact with the crown. Check to ensure that no leakage can be heard.
7. Apply a 1/8" slotted blade screwdriver to turn the adjustment screw (11) counterclockwise to initiate a very slight leak. Then turn the adjustment screw back clockwise in very small increments of adjustment, only until the exact point where the leak stops. Purge the second stage to ensure the leak does not return, and then turn the adjustment screw exactly **three** 360° full turns clockwise further from the point where the leak stopped.



**CAUTION:** Over-adjustment of the adjustment screw can cause excessive spring load in a second stage valve, and may severely degrade the performance of the regulator.

8. Purge the second stage regulator several times and listen for any leaks. Check the lever height again, and perform any follow-up adjustments as needed to eliminate leakage.
9. Turn the air supply valve completely shut, and check to ensure that the H.A.B.D. valve remains shut to the "OFF" position. Purge the second stage to depressurize the system, and remove the in-line adjustment tool and second stage from the IP hose.



**NOTE:** Correct intermediate pressure for the H.A.B.D. is 140 +/- 5 psi, with an inlet pressure of 3,000 psi.

## FINAL ASSEMBLY - SECOND STAGE (Right Hand & Left Hand Models)

1. Disconnect the in-line adjustment tool from the second stage and the IP hose.
- 2a. **(LH Model)** - Install the O-ring (10) securely into the groove of the cap plug (9). Thread the cap plug clockwise into the female threaded end of the valve body (23). Apply a torque wrench with 5/32" hex key to tighten the cap plug to a torque measurement of **30 ± 3 inch-lbs.**
- 2b. **(RH Model)** - Install the O-ring (10) securely inside the groove between the female threaded end of the valve body and the box bottom. Thread the cap plug (9) clockwise into the valve body, and apply the blade of the Micra Retaining Ring Tool (PN 100188) to tighten the cap nut snug, so that it is seated flush against the box bottom.
3. While holding the box bottom secure, apply a torque wrench with 13/16" socket (LH) or 3/4" socket (RH) to tighten the hex nut snug to a torque measurement of **45 +/- 2 inch-lbs.**
4. Connect the female fitting of the IP hose to the second stage inlet. While holding the hex nut of the second stage secure with a 13/16" or 3/4" open-end wrench, apply a torque wrench with 11/16" crow-foot to tighten the IP hose fitting to a torque measurement of **45 +/- 3 inch-lbs.**
5. Install the diaphragm (4) into the box bottom with its raised center facing up, and check to ensure it is evenly seated onto the shoulder at the base of the threads.
6. Place the purge cover (3) directly over the diaphragm, and rotate it as needed to align the holes horizontally straight.
7. After rinsing the retaining ring in soapy water, fit the retaining ring (2) down over the purge cover with the slotted side facing up, and apply one pin of the Micra retaining ring tool (PN 100188) to one of the slots. While holding the purge cover securely in place, turn the retaining ring clockwise until it is lightly snug (see Figure 54). Check to ensure that the purge cover has not rotated and correct if necessary before applying both pins of the tool to tighten the retaining ring completely snug. Slight rotation of the purge cover is not critical.

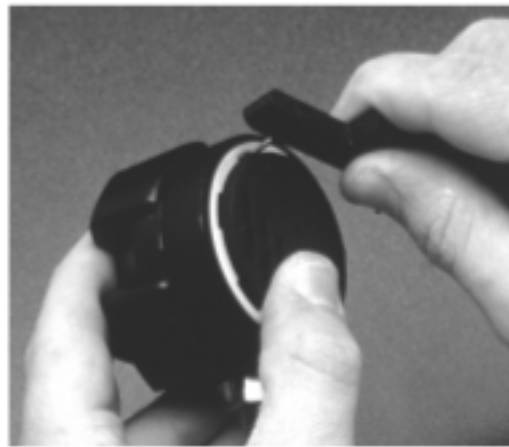



Figure 54 - Installation of retaining ring

8. Thread the purge guard (1) onto the box bottom and turn clockwise by hand until snug.

## Final Testing Procedures

 **NOTE:** If an accurately calibrated airflow test bench is not available, proceed directly to Step 4.

1. **Second Stage Air Flow Test** - With the H.A.B.D. still connected to the test bench, pressurize the system to 3,000 +/- 100 psi. Place the second stage mouthpiece over the mouthpiece adapter. Slowly turn the flowmeter control knob until the flow reaches a minimum of 8 SCFM (425 liters per minute). The reading on the Magnahelic gauge (inhalation / exhalation effort gauge) should indicate no more than +5.5" H<sub>2</sub>O. If the reading exceeds +5.5" H<sub>2</sub>O, refer to **Table 1 - Troubleshooting** for corrective guidelines and specific procedures.
2. **Second Stage Opening Effort Test** - Turn the flowmeter control knob shut, and then slowly reopen while watching both the Magnahelic gauge and the intermediate pressure gauge. When the intermediate pressure gauge begins to drop below the intermediate pressure "lockup," the magnahelic gauge should indicate an opening effort of 1.6" of H<sub>2</sub>O to 2.2" of H<sub>2</sub>O. If the opening effort is not within this range, refer to **Table 1 - Troubleshooting.**
3. **Second Stage Purge Flow Test** - Turn off the flowmeter control knob. Next, while the second stage is still mounted on the mouthpiece adapter, watch the flowmeter gauge and fully depress the purge cover. The flowmeter gauge must indicate a minimum of +4.0 SCFM (142 L.P.M.) If the purge flow is less than +4.0 SCFM, refer to **Table 1 - Troubleshooting.** When purge flow is correct, remove the second stage from the mouthpiece adapter on the flow test bench.

4. **Subjective Breathing Test** - Inhale from the second stage while the system is pressurized with 3,000 psi. A properly serviced and adjusted H.A.B.D. should deliver air upon deep inhalation without freeflow, hesitation, or “fluttering” of the second stage diaphragm. When exhaling, there should be no noticeable resistance felt. If any of these problems occur, refer to **Table 1 - Troubleshooting**. Also, depress the purge cover fully to ensure that an adequate volume of air needed to clear the second stage flows through the mouthpiece.
5. Sterilize regulator IAW local instructions prior to storage or issue.

## PRESSURE GAUGE INSTALLATION & EXTERNAL LEAK TEST

1. After final reassembly and adjustment of the H.A.B.D. is completed, fill the H.A.B.D. with 3,000 psi directly from the flow bench or according to the procedures outlined in the H.A.B.D. Owner’s Manual. Turn the H.A.B.D. valve to the “OFF” position, and depressurize the air supply and H.A.B.D. second stage before removing the fill adapter.
2. Mate the threaded end of the pressure gauge assembly into the open HP port and turn clockwise by hand until finger snug. Apply a torque wrench with 11/16” socket to tighten the pressure gauge assembly to a torque measurement of **45 +/- 3 inch-lbs.** DO NOT OVERTIGHTEN.
3. Turn the H.A.B.D. valve to the “ON” position to repressurize, and check the pressure gauge to ensure that the H.A.B.D. cylinder is completely filled to 3,000 psi.
4. Submerge the entire system in a test tank of clean water while pressurized in the “ON” position. Observe any bubbles arising from the submerged system over a minimum one minute period. The recommended time is necessary due to slower bubble formation that occurs in smaller leaks. Bubbles indicate a leak, which requires that the system must be disassembled at the source to check sealing surfaces, assembly sequence and component positioning in order to correct the problem(s).
5. As a final test, leave the unit pressurized in the “ON” position at a stable temperature for a period of at least twelve hours, and check the pressure gauge to determine whether any air loss occurs.



**WARNING:** The H.A.B.D. is designed to assist helicopter crewmembers and passengers in emergency egress situations from submerged aircraft. It is very critical to ensure that no leakage is present, and that the unit has met all requirements in the Final Testing Procedures outlined above. **DO NOT** issue to a crewmember or passenger any H.A.B.D. which exhibits any signs of leakage or unsatisfactory performance until the problem has been thoroughly diagnosed and repairs have been made as needed, including the possible replacement of a damaged component or subassembly.

This concludes annual service procedures for the H.A.B.D.

**Table 1**  
**Troubleshooting Guide**  
**H.A.B.D. Second Stage**

SYMPTOM	POSSIBLE CAUSE	TREATMENT
Leakage or freeflow from second stage.	<ol style="list-style-type: none"> <li>1. High first stage intermediate pressure. (should be 140 +/- 5 psi)</li> <li>2. LP seat (15) damaged or worn.</li> <li>3. Adjustment screw (11) incorrectly adjusted.</li> <li>4. Lever (5) set too high.</li> <li>5. Lever (5) damaged.</li> <li>6. Crown (25) sealing surface damaged or worn.</li> <li>7. Poppet (14) damaged or worn.</li> <li>8. Poppet spring (13) damaged.</li> </ol>	<ol style="list-style-type: none"> <li>1. Refer to first stage Troubleshooting Guide.</li> <li>2. Replace LP seat.</li> <li>3. Readjust adjustment screw per final tuning &amp; testing instructions.</li> <li>4. Readjust crown (25) per final tuning &amp; testing instructions.</li> <li>5. Disassemble second stage and replace lever.</li> <li>6. Replace crown.</li> <li>7. Replace poppet &amp; LP seat.</li> <li>8. Replace poppet spring.</li> </ol>
Low purge or excessive work of breathing (full cylinder)	<ol style="list-style-type: none"> <li>1. Low intermediate pressure. (should be 140 +/- 5 psi)</li> <li>2. Poppet spring adjustment screw (11) incorrectly adjusted.</li> <li>3. Lever (5) set too low.</li> <li>4. Lever (5) bent.</li> <li>5. Poppet spring (13) incorrectly installed.</li> <li>6. Intermediate pressure hose clogged or obstructed.</li> </ol>	<ol style="list-style-type: none"> <li>1. Refer to first stage Troubleshooting Guide.</li> <li>2. Readjust adjustment screw per final tuning &amp; testing instructions.</li> <li>3. Readjust crown (25) per final tuning &amp; testing instructions.</li> <li>4. Disassemble second stage and replace lever.</li> <li>5. Disassemble second stage and reinstall poppet spring.</li> <li>6. Clean or replace hose.</li> </ol>
External air leakage (Immersion Test)	<ol style="list-style-type: none"> <li>1. Intermediate pressure hose loose.</li> <li>2. IP hose O-ring (28) damaged.</li> <li>3. IP hose (?) leaking.</li> </ol>	<ol style="list-style-type: none"> <li>1. Tighten to 45 inch-lbs at second stage fitting.</li> <li>2. Disassemble and replace O-ring.</li> <li>3. Replace hose.</li> </ol>

**Table 1**  
**(Continued)**

SYMPTOM	POSSIBLE CAUSE	TREATMENT
Water entering second stage	<ol style="list-style-type: none"> <li>1. Hole in mouthpiece (18).</li> <li>2. Demand diaphragm (4) damaged.</li> <li>3. Exhaust diaphragm (7) damaged.</li> <li>4. Anti-venturi vane O-ring (21) dirty, damaged, or worn.</li> <li>5. Diaphragm improperly seated between box bottom (22) and purge cover (3).</li> <li>6. Box bottom damaged. (Check exhaust valve sealing surface.)</li> <li>7. Valve body O-ring (24) damaged.</li> <li>8. End cap O-ring (10) damaged.</li> </ol>	<ol style="list-style-type: none"> <li>1. Replace mouthpiece.</li> <li>2. Replace demand diaphragm.</li> <li>3. Replace exhaust diaphragm(s).</li> <li>4. Replace O-ring.</li> <li>5. Disassemble and properly assemble. (Check for distortion).</li> <li>6. Replace box bottom.</li> <li>7. Disassemble and replace O-ring.</li> <li>8. Disassemble and replace O-ring.</li> </ol>



**NOTE:** This is a partial list of possible problems and recommended treatments. For more information, refer to the first stage troubleshooting guide, or contact Aqua Lung's Technical Services Department for assistance with problems not described here.



**CAUTION:** Recommended treatments which require disassembly of the regulator must be performed during a complete overhaul, according to the prescribed procedures for scheduled, annual service. Do not attempt to perform partial service.

**Table 2**  
**Troubleshooting Guide**  
**H.A.B.D. First stage / Valve assembly**

SYMPTOM	POSSIBLE CAUSE	TREATMENT
System will not remain depressurized after valve is shut and second stage is purged.	<ol style="list-style-type: none"> <li>1. Indicator ring (15) set incorrectly.</li> <li>2. Valve body (28) is damaged or worn.</li> <li>3. Crown sealing surface of cylinder adapter (32) orifice is damaged.</li> </ol>	<ol style="list-style-type: none"> <li>1. Loosen set screw (12) and reset indicator ring.</li> <li>2. Replace valve body.</li> <li>3. Replace cylinder adapter.</li> </ol>
High or unstable intermediate pressure.	<ol style="list-style-type: none"> <li>1. First stage improperly adjusted.</li> <li>2. HP seat (21) damaged or worn.</li> <li>3. Spring block O-ring (23) damaged or worn.</li> <li>4. Spring block (25) internal surface damaged.</li> <li>5. Crown sealing surface of first stage body (10) damaged.</li> <li>6. Springblock springs (22 &amp; 26) weakened or damaged.</li> </ol>	<ol style="list-style-type: none"> <li>1. Readjust adjustment screw (1).</li> <li>2. Replace HP seat.</li> <li>3. Replace spring block O-ring.</li> <li>4. Replace spring block.</li> <li>5. Polish w/ tool (PN 105997) or replace first stage body.</li> <li>6. Replace springblock springs.</li> </ol>
Low intermediate pressure.	<ol style="list-style-type: none"> <li>1. Adjustment screw (1) incorrectly adjusted.</li> <li>2. Main spring (4) weakened or damaged.</li> <li>3. Spring retainer (2) loose.</li> </ol>	<ol style="list-style-type: none"> <li>1. Readjust adjustment screw per final tuning &amp; testing instructions.</li> <li>2. Replace main spring.</li> <li>3. Tighten to 25 +/- 2 ft-lbs.</li> </ol>
External air leakage (Immersion Test)	<ol style="list-style-type: none"> <li>1. Spring retainer (2) loose.</li> <li>2. Diaphragm (7) worn or damaged.</li> <li>3. Diaphragm seating surface inside first stage body (10) damaged.</li> </ol>	<ol style="list-style-type: none"> <li>1. Tighten to 25 +/- 2 ft-lbs.</li> <li>2. Replace diaphragm.</li> <li>3. Replace first stage body.</li> </ol>



**NOTE:** This is a partial list of possible problems and recommended treatments. For more information, contact Aqua Lung's Technical Services Department for assistance with problems not described here.



**CAUTION:** Recommended treatments which require disassembly of the regulator must be performed during a complete overhaul, according to the prescribed procedures for scheduled, annual service. Do not attempt to perform partial service.

**Table 3**  
**Recommended Tool List**  
**H.A.B.D.**

<b>PART NO.</b>	<b>DESCRIPTION</b>	<b>APPLICATION</b>
1116-10	I.P. test gauge	Intermediate pressure testing
1006-55	SCUBA Fill Adapter	Intermediate pressure testing, filling
N/A	0-120 inch-lbs torque wrench	Small fittings
N/A	10-50 ft-lbs torque wrench	Large fittings
9440-22	O-ring tools	O-ring removal & installation
100397/100398	Bottle vise / Vise Insert	First stage disassembly / reassembly
1003-95	Vise mounting tool	First stage disassembly / reassembly
13220 w/ 1020-85	CO2 cartridge w/ HP adapter	(Can be used instead of vise mounting tool)
N/A	LP air nozzle	Burst disc & diaphragm removal
9-BA819008	Magnifier w/ illumination	Sealing surface inspection
N/A	Ultrasonic cleaner	Brass & stainless steel parts cleaning
N/A	3/16" blade screwdriver	2nd stage crown
N/A	1/8" blade screwdriver	2nd stage adjustment screw
N/A	5/16" blade screwdriver	1st stage adjustment screw
9-44584 / 9-43226	3/4" open-end wrench / socket	1st stage valve body
N/A	13/16" open-end wrench & socket	2nd stage hex nut
N/A	11/16" open-end wrench & socket	IP hose fitting
N/A	1/16" hex key	Indicator ring set screw
N/A	5/32" hex key & socket	LP Swivel Port, 2nd stage cap plug
1111-00	Reversible snap ring pliers	Hose retaining ring, fill adapter filter circlip
9-44385	1/2" open-end wrench & socket	Safety plug
N/A	1 1/8" open-end wrench & socket	Cylinder adapter
N/A	1" open-end wrench & socket	Spring retainer
54325A22	Strap wrench	Cylinder
1001-95	In-line adjustment tool	2nd stage tuning
1001-88	Retaining ring tool	Retaining ring removal & installation
1094-36	Seat extraction / installation tool	2nd stage crown
1001-68	Micra pre-adjustment tool	Anti-venturi vane clip, crown & screw setting
1028-68	Lever height gauge	Lever height adjustment
820466	Christo-Lube® 2.0 oz tube	Lubrication

**Table 4**  
**Standard Parts Replacement**  
**H.A.B.D.**

PART NO.	DESCRIPTION	KEY NUMBER	QTY
1034-25 (A)	Thrust Washer	6 (1st stage)	1
1034-25 (B)	Diaphragm	7 (1st stage)	1
0502-41	Safety Disc Assembly	11 (1st stage)	1
8203-19	O-ring	13 (1st stage)	1
8203-11	O-ring	16 (1st stage)	1
8203-12	O-ring	18 (1st stage)	2
8600-65	Hose Retaining Ring	20 (1st stage)	1
1053-21	High Pressure Seat	21 (1st stage)	1
8203-06	O-ring	23 (1st stage)	1
8280-05	Backup Ring	24 (1st stage)	1
8203-14	O-ring	27 (1st stage)	1
8285-10	Backup Ring	29 (1st stage)	1
820316	O-ring	33 (1st stage)	1
8203-10	O-ring	30 (1st stage), 21, 26, & 28 (2nd stage)	4
1001-22	Exhaust Valve	7 (2nd stage)	2
8200-17	O-ring	10 (2nd stage) (Left Hand)	1
1067-38	Low Pressure Seat	15 (2nd stage)	1
1049-13	Clamp	17 (2nd stage)	1
8200-15	O-ring	24 (2nd stage) (Left Hand)	1
820016	O-ring	10 (2nd stage) (Right Hand)	1

**Table 5**  
**Torque Specifications**  
**H.A.B.D.**

PART NO.	DESCRIPTION / KEY NUMBER	TORQUE
1006-05	Cylinder Adapter / 32 (1st Stage)	25 (+/- 2) ft-lbs
1028-22	Valve Body / 28 (1st Stage)	60 (+/- 3) inch-lbs
1006-27	Spring Retainer / 2 (1st Stage)	25 (+/- 2) ft-lbs
7425-38	Pressure Gauge / 14 (1st Stage)	45 (+/- 3) inch-lbs
0502-41	Safety Plug / 11c (1st Stage)	90 (+/- 5) inch-lbs
1028-12	LP Port Swivel / 17 (1st Stage)	60 (+/- 3) inch-lbs
1006-25	IP hose / 19 (1st Stage)	45 (+/- 3) inch-lbs
1001-36	Hex Nut / 24 (2nd Stage)	45 (+/- 3) inch-lbs
1002-62	Cap Plug / 9 (2nd Stage) (Left Hand)	30 (+/- 2) inch-lbs

**Table 6**  
**Test Bench Specifications**  
**H.A.B.D.**

<b>TEST</b>	<b>CONDITION</b>	<b>ACCEPTABLE RANGE</b>
Leak test	Inlet 2,500-3,000 (+/- 100) psi	None
Intermediate pressure	Inlet 2,500-3,000 (+/- 100) psi	140 (± 5) psi
Intermediate pressure creep	Inlet 2,500-3,000 (+/- 100) psi	5 psi max between 5 to 15 seconds after cycling regulator (purge)
Opening effort	Inlet 2,500-3,000 (+/- 100) psi, intermediate pressure 140 (+/- 5) psi	+1.6 to +2.2 inch H <sub>2</sub> O
Flow effort	Intermediate pressure 140 (+/- 5) psi at 8 SCFM	+5.5 inches H <sub>2</sub> O (maximum)
Purge flow	Intermediate pressure 140 (+/- 5) psi	4.0 SCFM flow rate (minimum)

## Procedure A Cleaning & Lubrication (H.A.B.D.)

1. **Acid Bath** - Aqua Lung® strongly recommends Oakite Cleaner for cleaning all reusable brass and stainless steel parts. Oakite is a specially formulated cleaner that does not harm rubber or Teflon parts, yet effectively removes silicone grease, corrosion, and grime from metal parts, leaving only a brilliant shine. For best results, soak parts in an ultrasonic cleaner for 5 to 15 minutes, unless the chrome finish is chipped or flaking. Parts with damage to their chrome finish should be cleaned separately outside the ultrasonic cleaner to avoid agitation. Be certain to isolate more delicate parts, such as orifice cones, to prevent damage to sealing surfaces.



**CAUTION:** Harsh acids, such as muriatic acid, may cause damage to parts and must be strictly avoided. White vinegar, although less effective, is one suitable substitute for Oakite.



**CAUTION:** Ultrasonic cleaning times in excess of 15 minutes may damage the chrome finish of certain parts. Be certain to use a timer, and do not leave parts unattended while cleaning.



**NOTE:** *Although Oakite contains a degreasing agent, cleaning heavily greased parts in Oakite will shorten the effective life of the solution, and require it to be replaced on a more frequent basis. Heavily greased parts may be degreased in a solution of warm water and mild dish detergent prior to being placed in the acid bath.*

2. **Fresh Water Rinse** - If tap water is extremely “hard,” distilled water may be used to prevent any mineral residue. Remove parts from the acid bath and place directly into this rinse. Agitate lightly, and allow to soak for 5-10 minutes. Remove and blow dry with low pressure (25 psi) filtered air, and inspect closely to ensure proper cleaning and like-new condition.

### ANODIZED ALUMINUM, PLASTIC & RUBBER PARTS

Anodized aluminum parts and parts made of plastic or rubber, such as box bottoms, box tops, dust caps, etc., may be soaked and cleaned in a solution of warm water mixed with mild dish soap. Use only a soft nylon toothbrush to scrub away any deposits. Thoroughly blow dry, using low pressure filtered air.

### HOSES

If buildup of corrosion is severe, it is permissible to soak only the hose fittings in Oakite cleaner as needed, and not allow any solution to enter the hose. Rinse in fresh water and allow to dry with the cleaned ends hanging down. Blow filtered air through them prior to installing onto the regulator.



### LUBRICATION AND DRESSING

All O-rings must be lubricated only with Christo-Lube® MCG-111 grease, which meets requirements for extreme weather conditions. Dress every O-ring with a visible film of grease, but avoid applying excessive amounts, as this will attract particulate matter that may cause damage to the O-ring.



**CAUTION:** Silicone grease and sprays must be strictly avoided for the H.A.B.D., since silicone does not provide adequate lubricity in extreme weather conditions.

**Table A**  
**Recommended Lubricants & Cleaners**  
**H.A.B.D.**

LUBRICANT / CLEANER	APPLICATION	SOURCE
Christo-Lube® MCG-111	All O-ring seals; cylinder valve threads	PN 820466 (2.0 oz tube) or Lubrication Technologies 310 Morton Street Jackson, OH 45640 (800) 477-8704
<div style="border: 1px solid black; padding: 5px;">  <b>CAUTION:</b> Silicone rubber requires no lubrication or preservative treatment. DO NOT apply grease or spray to silicone rubber parts. Doing so may cause a chemical breakdown and premature deterioration of the material.         </div>		
Anti-Seize Lubricant #80208	H.A.B.D. cylinder adapter - female threads	Permatex Industrial Corp. 10 Columbus Blvd. Hartford, CT 06106 (860) 520-5000
<div style="border: 1px solid black; padding: 5px;">  <b>CAUTION:</b> Anti-seize lubricant can cause premature deterioration of O-ring materials. Be careful when applying to remove any excess and clean hands afterward if necessary before handling other parts to prevent any contact between residue and O-rings.         </div>		
Oakite #31	Acid bath for reusable stainless steel and brass parts.	Oakite Products, Inc. 50 Valley Road Berkeley Heights, NJ 07922
White distilled vinegar (100 gr.)	Acid bath for reusable stainless steel and brass parts.	"Household" grade
<div style="border: 1px solid black; padding: 5px;">  <b>CAUTION:</b> DO NOT use muriatic acid for the cleaning of any parts. Muriatic acid, even when strongly diluted, can harm chrome plating, and may leave a residue that is harmful to O-ring seals and other parts.         </div>		
Liquid dishwashing detergent (diluted with warm water)	Degreaser for brass and stainless steel parts, general cleaning solution for plastic, rubber, and anodized aluminum parts.	"Household" grade

## H.A.B.D. First Stage with Cylinder Assembly

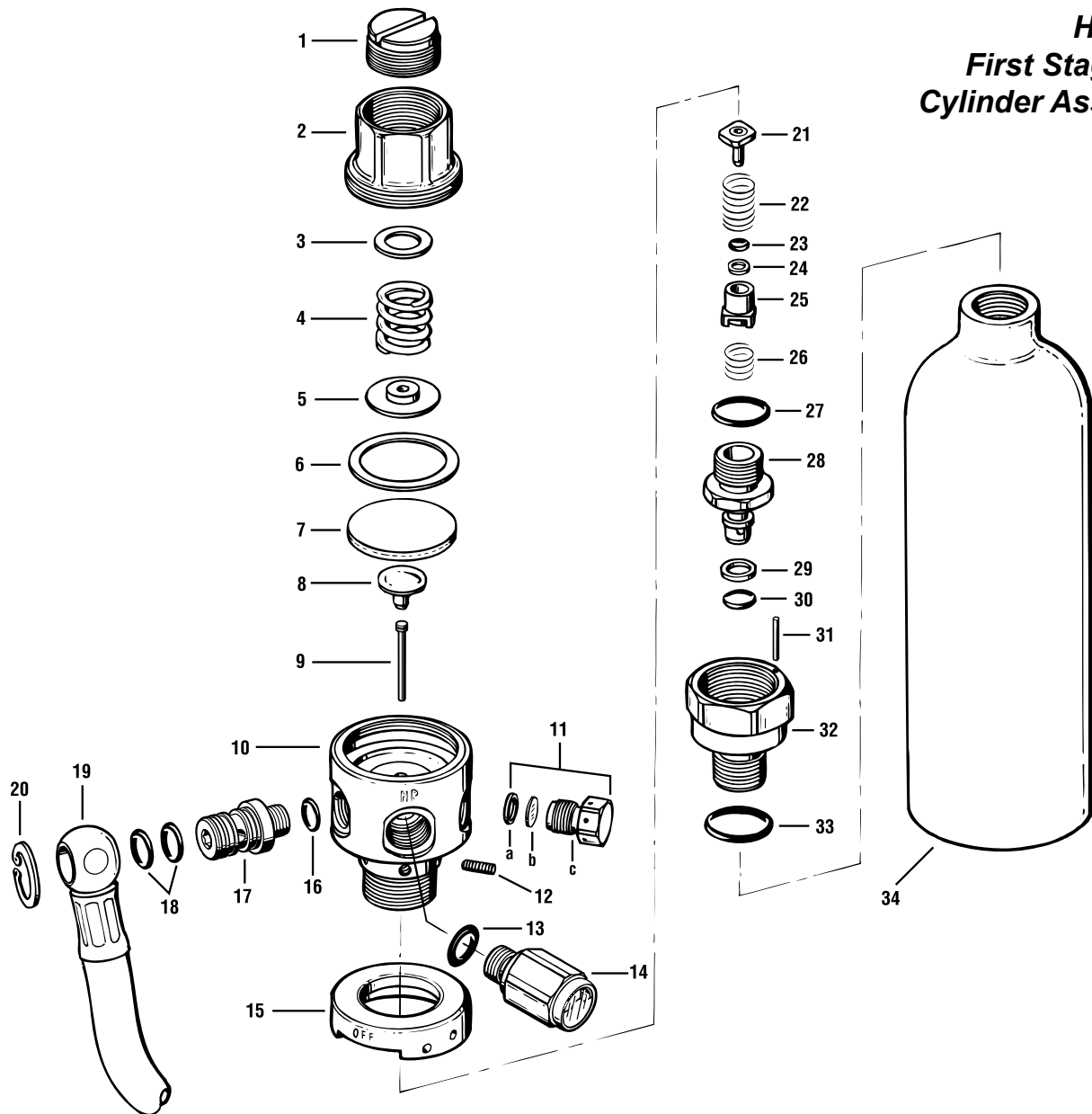

Key #	Part #	Description	Key #	Part #	Description
---	102881	Overhaul Kit, 1st STG, HABD/SRU-40B/P	19	102835	Hose Assy 20"
---	211962	Overhaul Service Kit, HABD First Stage (10pk) CF-MAS	<b>20</b>	<b>860065</b>	<b>Hose Retaining Ring</b>
---	102871	1st Stage Assy, HABD/SRU-40B/, Spare	<b>21</b>	<b>105321</b>	<b>HP Seat, Black Rubber</b>
1	106023	Adjustment Screw	22	101504	Spring
2	100627	Spring Retainer	<b>23</b>	<b>820306</b>	<b>O-ring</b>
3	845097	Washer, Nylon, Main Spring	<b>24</b>	<b>828005</b>	<b>Back-up Ring</b>
4	105327	Main Spring	25	105324	HP Spring Block
5	101728	Spring Pad	26	104613	Spring
<b>6</b>	<b>103425(A)</b>	<b>Thrust Washer</b>	<b>27</b>	<b>820314</b>	<b>O-ring</b>
<b>7</b>	<b>103425(B)</b>	<b>Diaphragm</b>	28	102822	Valve Assy
8	101727	Pin Support	<b>29</b>	<b>828510</b>	<b>Backup Ring</b>
9	102823	Pin	<b>30</b>	<b>820310P</b>	<b>O-ring (10 pk)</b>
10	100601	Body, First Stage	31	100609	Indicator Pin
<b>11</b>	<b>050241</b>	<b>Safety Disc Assy, 3000 psi</b>	32	100605	Cylinder Adapter
12	100623	Set Screw	<b>33</b>	<b>820316P</b>	<b>O-ring (10 pk)</b>
<b>13</b>	<b>820319P</b>	<b>O-ring (10 pk)</b>	34	079105	1.5 cf Cylinder, Black
14	102873	Pressure Gauge Assy	N/S	100699	Retrofit Kit, Extreme Weather, SRU-40A/P
15	100614	Ring Indicator			
<b>16</b>	<b>820311P</b>	<b>O-ring (10 pk)</b>			
17	102812	LP Port Swivel (w/Hex Slot)			
<b>18</b>	<b>820312P</b>	<b>O-ring (10 pk)</b>			

Part numbers in **BOLD ITALICS** indicate standard overhaul replacement parts.

**H.A.B.D.  
Second Stage  
(LH Version)**

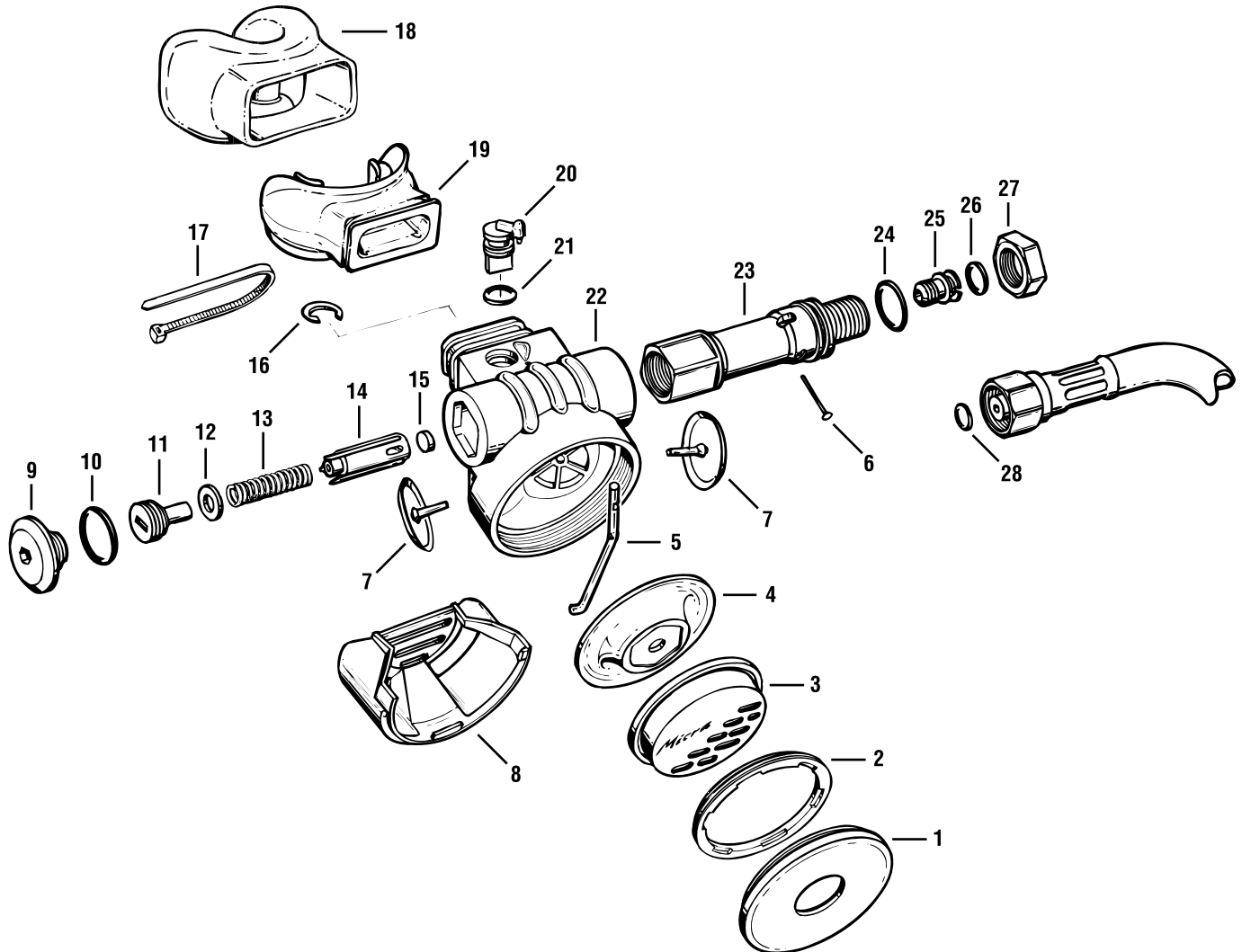

Key #	Part #	Description
----	102882	Service Kit, HABD 2nd Stage-SRU 40B/P
----	102872	2nd Stage Assy,HABD/SRU-40B/P,SPARE
----	100699	Retrofit Kit, Extreme Weather, SRU-40A/P
1 ---	100652	Cover Hard Purge Guard
2 ---	100119	Ring, Retainer
3 ---	100104	Cover Front
4 ---	100181	Demand Diaphragm
5 ---	100257	Lever, Coated, Left
6 ---	100132	Pin
7 ---	<b>100122</b>	<b>Valve Exhaust, 1.0"</b>
8 ---	100109	Exhaust Cover
9 ---	100262	Cap plug, Left, Chrome
10 ---	<b>820017P</b>	<b>O-ring (10pk)</b>
11 ---	100223	Adjustment Screw (black)
12 ---	100173	Washer, Red
13 ---	100134	Spring
14 ---	100127	Poppet
15 ---	<b>106738</b>	<b>Disc Seat</b>

Key #	Part #	Description
16 ---	860137	Retaining Ring
17 ---	<b>104913</b>	<b>Clamp, Strap, Black</b>
18 ---	100653	Mouthpiece Cover
19 ---	105831	Mouthpiece
20 ---	100108	Vane Adjusting, (Anti-Venturi)
21 ---	<b>820310P</b>	<b>O-ring (10 pk)</b>
22 ---	102844	Box Bottom (6 spokes)
23 ---	100245	Valve Body, Left
24 ---	<b>820015P</b>	<b>O-ring (10 pk)</b>
25 ---	100128	Crown Orifice
26 ---	<b>820310P</b>	<b>O-ring (10 pk)</b>
27 ---	100236	Hex Nut, 13/16", Left
28 ---	<b>820310P</b>	<b>O-ring (10 pk)</b>

Part numbers in **BOLD ITALICS** indicate standard overhaul replacement parts.

**H.A.B.D.  
Second Stage  
(RH Version)**

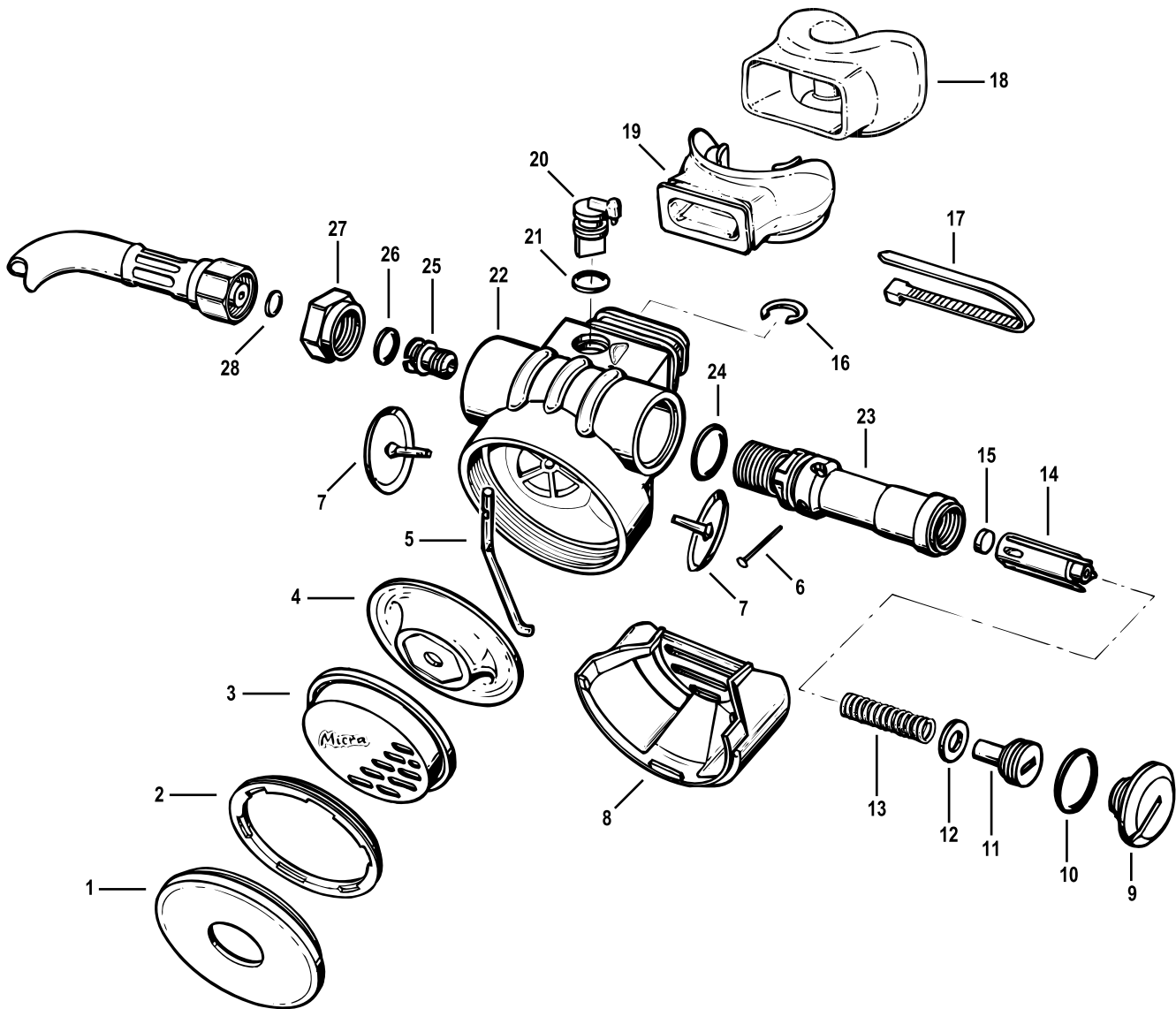

Key #	Part #	Description	Key #	Part #	Description
----	211961	Overhaul, Second Stage, CF-MAS (RH) (10PK)	16 ----	860137	Retaining Ring
----	100699	Retrofit Kit, SRU-40A/P	17 ----	<b>104913</b>	<b>Clamp, Strap, Black</b>
1 ----	100652	Cover Hard Purge Guard	18 ----	100653	Mouthpiece Cover
2 ----	100119	Ring, Retainer	19 ----	105831	Mouthpiece, Black
3 ----	100104	Cover Front	20 ----	100108	Vane Adjusting, (Anti-Venturi)
4 ----	100181	Demand Diaphragm	21 ----	<b>820310P</b>	<b>O-ring (10 pk)</b>
5 ----	100157	Lever Teflon® Coated	22 ----	102844	Box Bottom (6 spokes)
6 ----	100132	Pin	23 ----	100145	Valve Body
7 ----	<b>100122</b>	<b>Exhaust Valve 1.0"</b>	24 ----	<b>820314</b>	<b>O-ring</b>
8 ----	100109	Exhaust Cover	25 ----	100128	Crown Orifice
9 ----	100162	Cap Plug, Right, Black	26 ----	<b>820310P</b>	<b>O-ring (10 pk)</b>
10 ----	<b>820016P</b>	<b>O-ring (10 pk)</b>	27 ----	100136	Hex Nut, 3/4"
11 ----	100123	Adjustment Screw (white)	28 ----	<b>820310P</b>	<b>O-ring (10 pk)</b>
12 ----	100173	Washer, Red			
13 ----	100134	Spring			
14 ----	100127	Poppet			
15 ----	<b>106738</b>	<b>Disc Seat</b>			

Part numbers in **BOLD ITALICS** indicate standard overhaul replacement parts.

---

## Maintenance Notes

---

## Maintenance Notes



Helicopter Aircrew Breathing Device  
(H.A.B.D.)  
Service and Repair Manual



Aqua Lung® • 2340 Cousteau Court, Vista, CA 92081 • Telephone: (760) 597.5000 • Fax: (760) 597.4900  
[www.aqualung.com/militaryandprofessional](http://www.aqualung.com/militaryandprofessional)