

# MRS III

## Mobile Refill System for the Aqua Lung SEA (Survival Egress Air)



# Operation and Maintenance Manual

October, 2011



# TABLE OF CONTENTS

<b>SECTION 1</b> .....	<b>1</b>
DESCRIPTION OF UNIT.....	1
<b>SECTION 2</b> .....	<b>1</b>
CONFIGURATION.....	1
FIGURE 1, MRS III UNIT .....	1
<b>SECTION 3</b> .....	<b>2</b>
PREPARATION FOR USE.....	2
FIGURE 2, CYLINDER HYDROSTAT STICKER.....	2
<b>SECTION 4</b> .....	<b>2</b>
MRS III OPERATING INSTRUCTIONS.....	2
<b>SECTION 5</b> .....	<b>2</b>
OPERATION .....	2
OPENING VALVES.....	2
CONNECTING FILL HOSES .....	2
FIGURE 3, OPENING SUPPLY CYLINDER VALVES .....	2
LEAKING FITTINGS.....	3
BLEEDER VALVES .....	3
FIGURE 4, CONNECTING SEA FILL HOSES .....	3
FIGURE 5, CLOSE BLEEDER VALVE .....	3
FIGURE 6, OPEN PANEL-MOUNTED VALVES .....	3
FIGURE 7, FILL PRESSURE GAUGE .....	3
<b>SECTION 6</b> .....	<b>3</b>
REFILLING SUPPLY CYLINDERS.....	3
CHECK HYDROSTAT DATE.....	3
VISUAL INSPECTION .....	3
FILL ADAPTERS .....	3
FIGURE 8, FILL ADAPTER.....	4
FIGURE 9, REMOVE RUBBER CAP .....	4
FIGURE 10, CONNECT TO AIR INLET FITTING.....	4
FIGURE 11, CHECK SUPPLY AIR PRESSURE .....	4
<b>SECTION 7</b> .....	<b>4</b>
AFTER FILLING IS COMPLETED .....	4
FIGURE 12, DRAINING FILL HOSE.....	5
FIGURE 13, PUTTING AWAY FILL HOSE .....	5
<b>SECTION 8</b> .....	<b>5</b>
WARNINGS.....	5
 <b>MRS III MAINTENANCE</b>	
<b>SECTION 9</b> .....	<b>6</b>
AFTER ONE YEAR, AND EVERY YEAR THEREAFTER.....	6
OVERHAUL SEA ADAPTERS.....	6
FIGURE 14, REPLACE FILL ADAPTER ASSEMBLY .....	6
FIGURE 15, PRS21-8 .....	6
INSTALLING SEALS .....	7
FIGURE 16, USING PRS21-8-1 .....	7
FIGURE 17, USING PRS21-8-2 .....	7
FIGURE 18, USING PRS21-8-3 .....	7
FIGURE 19, FINISHED SPINDLE AND BODY.....	7
<b>SECTION 10</b> .....	<b>8</b>
REPLACING BLEEDER VALVE SEAT.....	8
FIGURE 20, BLEEDER VALVE AND SEAT.....	8
<b>SECTION 11</b> .....	<b>8</b>
DISASSEMBLING UNIT.....	8
REMOVING TOP PLATE .....	8
FIGURE 21, REMOVE SCREWS FROM PLATE .....	8

FIGURE 22, REMOVE TOP PLATE .....	8
FIGURE 23, INSPECT FOAM PADDING .....	8
FIGURE 24, DISCONNECT CYLINDERS .....	9
REMOVING CYLINDERS .....	9
FIGURE 25, REMOVE CYLINDERS .....	9
CGA INSPECTION REQUIREMENTS .....	9
REINSTALL SUPPLY CYLINDER .....	9
FIGURE 26, CONNECTING O' RING.....	9
<b>SECTION 12 .....</b>	<b>10</b>
CYLINDER INSPECTION GUIDELINES.....	10
<b>SECTION 13 .....</b>	<b>10</b>
REMOVING UNIT FROM CASE.....	10
FIGURE 27, REMOVE SCREWS FROM BACK .....	11
FIGURE 28, REMOVE UNIT FROM CASE .....	11
<b>SECTION 14 .....</b>	<b>10</b>
GAUGE CALIBRATION .....	11
REMOVING GAUGES .....	11
FIGURE 29, REMOVE AND REPLACE GAUGE .....	11
REINSTALLING GAUGE.....	12
REINSTALLING UNIT .....	12
PRESSURE TEST.....	12
<b>SECTION 15 .....</b>	<b>12</b>
AFTER FIVE YEARS AND EVERY FIVE YEARS THEREAFTER.....	12
HYDROSTAT OF CYLINDERS .....	12
FILL VALVE MAINTENANCE.....	13
FIGURE 30, FILL VALVE ASSEMBLY.....	13
SUPPLY CYLINDER VALVES.....	14
FIGURE 31, SUPPLY CYLINDER VALVE .....	14
REMOVING SUPPLY CYLINDER VALVE .....	14
FIGURE 32, VAL1-10 TOOL.....	14
FIGURE 33, USING VAL1-10 .....	14
FIGURE 34, SUPPLY CYLINDER VALVE ASSEMBLY.....	15
FIGURE 35, VAL1-12 VALVE NUT TOOL .....	15
FIGURE 36, REMOVE BONNET W/VAL1-12 .....	15
FIGURE 37, REMOVE BONNET W/ WRENCH .....	15
REPLACING SAFETY DISC.....	16
FIGURE 38, SAFETY DISC PLACEMENT .....	16
SUPPLY VALVE GAUGE MAINTENANCE.....	16
FIGURE 39, VAL1-11 GAUGE TOOL .....	16
FIGURE 40, REMOVE GAUGE W/VAL1-11.....	16
FIGURE 41, SUPPLY CYLINDER GAUGE ASSEMBLY .....	17
<b>SECTION 16 .....</b>	<b>17</b>
MRS III REGULATOR.....	17
REMOVING FROM MRS III.....	17
FIGURE 42, REGULATOR ASSEMBLY .....	17
FIGURE 43, REGULATOR FITTINGS.....	18
FIGURE 44, ACORN NUT .....	18
FIGURE 45, 1120KIT-1 DETAIL.....	19
REASSEMBLE REGULATOR .....	19
PRESSURE TESTING.....	19
<b>SECTION 17 .....</b>	<b>19</b>
MRS III CASE .....	19
CASE WARRANTY INSTRUCTIONS.....	20
FIGURE 46, CASE LATCHES.....	20
FIGURE 47, HANDLE LATCH.....	20
FIGURE 48, CARRY HANDLES .....	20
FIGURE 49, HANDLE AND WHEELS .....	20

<b>TROUBLE SHOOTING CHART .....</b>	<b>21-23</b>
<b>ILLUSTRATED PARTS BREAKDOWN .....</b>	<b>24</b>
MRS III UNIT COMPLETE ASSEMBLY.....	26-28
INLINE BLEEDER ASSEMBLY .....	28
FILL VALVE .....	29
SUPPLY CYLINDER VALVE.....	30-31
SEA FILL ADAPTER .....	32
ONE-YEAR MAINTENANCE KIT.....	33
FIVE-YEAR MAINTENANCE KIT .....	33
955SSMM CHECK VALVE .....	34
PRS6.....	35
REGULATOR .....	36
MRS III FLOW DIAGRAM.....	37
PELICAN CASE, DIMENSIONS, TOP .....	38
PELICAN CASE, DIMENSIONS, BOTTOM.....	39

**WARNING:**

- This unit contains air under high pressure. Serious injury may result from misuse of this apparatus and the gas it contains.
- Avoid blowing compressed gas at yourself or any other person.
- Wear hearing protection.
- Avoid standing over top of the unit when it is in use.
- Have the gauges checked for accuracy every 18 months. They should be plus or minus 100psi.
- **Do not** overpressurize any compressed gas cylinder.
- **Do not** fill a damaged cylinder.
- **Do not** use this unit if the hoses are damaged.
- **Do not** fill this unit if the supply cylinders have not had the proper hydrostatic testing done within five years of today's date.

**WARNINGS, CAUTIONS, & NOTES**

Pay special attention to information provided in warnings, cautions, and notes that are accompanied by one of these symbols:



A **WARNING** indicates a procedure or situation that may result in serious injury or death if instructions are not followed correctly.



A **CAUTION** indicates any situation or technique that will result in potential damage to the product, or render the product unsafe, if instructions are not followed correctly.



A **NOTE** is used to emphasize important points, tips, and reminders



# MRS III

## Mobile Refill System

**1.0 DESCRIPTION OF UNIT:** The MRS III is designed to refill the Aqua Lung Survival Egress Air (SEA) LV, MK1.5, MK2, MK2.5. It has an internal supply of two carbon fiber composite 4500psi cylinders and has two preset regulated 3000psi fill lines. The control panel will allow you to monitor the pressure in the supply cylinders, verify the preset regulated pressure and control the filling of one or two SEA units.

**2.0 CONFIGURATION:** The attached picture shows the COMPLETE MRS III UNIT. The items lettered are listed below.

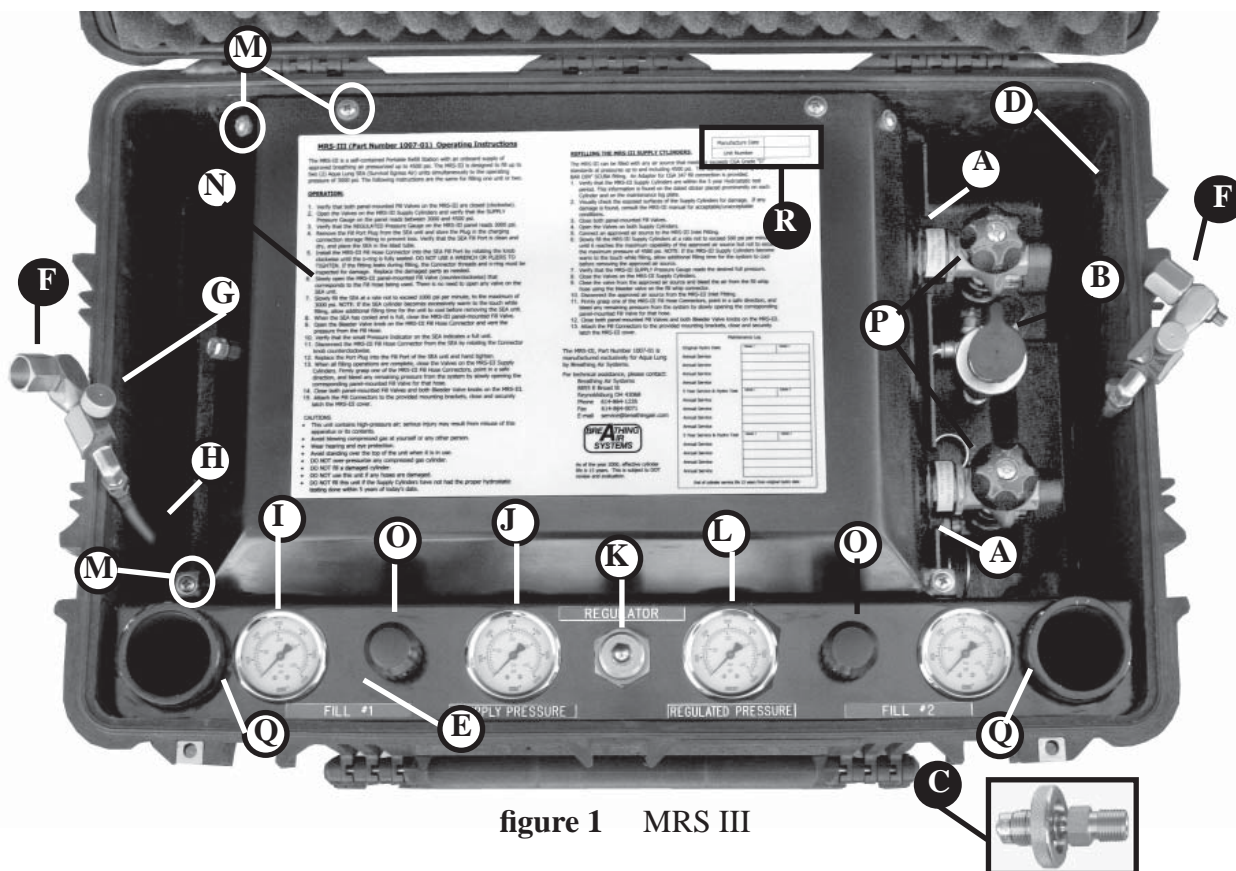

figure 1 MRS III

- |                                     |                                         |
|-------------------------------------|-----------------------------------------|
| A. Supply Cylinder (CYL1)           | J. Supply Pressure Gauge (GAG1)         |
| B. Refill Port w/ rubber cap (RCAP) | K. Preset regulator (1120)              |
| C. Adapter PRS6 to CGA 347          | L. Regulated Pressure Gauge (GAG1)      |
| D. Case (1650)                      | M. Fastener for top cover of the frame  |
| E. Frame/Control Panel (FRM1)       | N. Top Cover/ Instruction sheet         |
| F. SEA fill adapter (PRS21)         | O. Fill Valves (YVA3010A)               |
| G. Bleeder valves (712)             | P. Supply Cylinder Valves (VAL1)        |
| H. Fill Hose (HOS1)                 | Q. SEA Cylinder Holder/Burst Protector  |
| I. SEA Fill pressure Gauge (GAG1)   | R. Unit/serial number, Manufacture date |

△ NOTE: These identification letters do not match the I.D. numbers in the PARTS section, page 25

**3.0 PREPARATION FOR USE:** First unpack the unit and check for damage caused by shipping. Next, open the case.. Verify the hydrostatic test date of the supply cylinders, shown on a sticker prominently displayed on the cylinder (figure 2) and on the neck of supply cylinders (figure 3). This should also be written on the maintenance log, located on the lower right hand corner of the instruction sheet.

**△** 3.1 NOTE: THESE CYLINDERS (CYL1) REQUIRE HYDROSTATIC TESTING EVERY 5 YEARS, BY A DOT-APPROVED TEST FACILITY. CHECK DATE STICKER ON CYLINDER (figure 2), OR ON CYLINDER NECK. (figure 3)

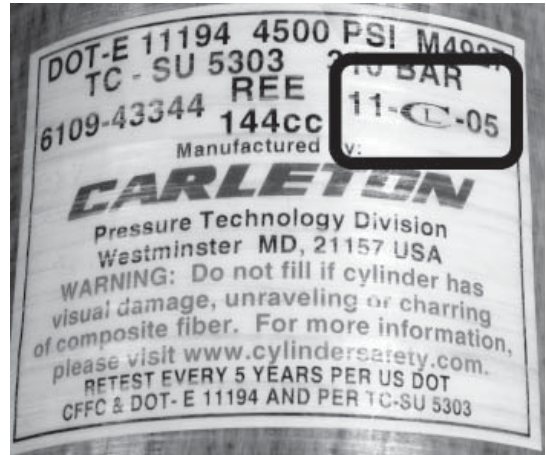

figure 2

3.2. Since the unit is shipped from the factory empty you must fill it with air (see Refilling Supply Cylinders, Section 6). The MRS III is now ready to fill SEA cylinders.

**4.0 MRS III OPERATING INSTRUCTIONS**

4.1. The purpose of this unit is to allow the filling either MK or LV series SEA cylinders to 3000psi from an internal source of approved breathing air. **You can fill either one or two at a time.**

**!** 4.1.1. WARNING-DO NOT FILL CYLINDERS THAT ARE DAMAGED OR THAT HAVE LIQUID IN THEM. THEY MUST BE INSPECTED ACCORDING TO MANUFACTURERS INSTRUCTIONS

**5.0 OPERATION:**

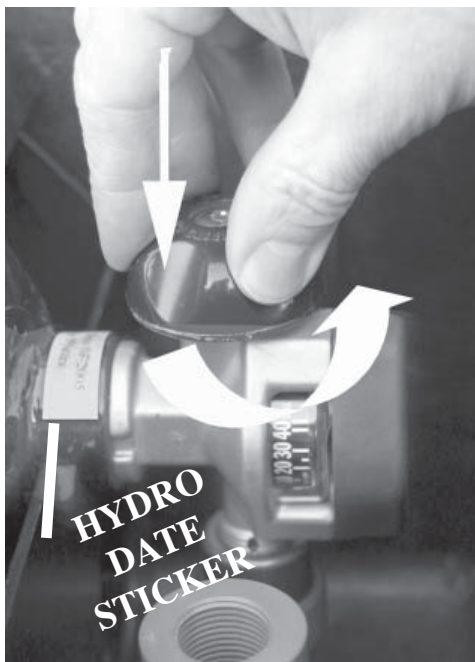

figure 3

5.1. Make sure the fill valves (YVA3010A) on the panel are closed.

5.2. Open the valves (VAL1) on the supply cylinders (figure 3). Valves lock in place when released. To release, push the knob while turning. Verify that the pressure in the supply cylinders is between 3000 and 4500psi .

5.3. Verify that the Regulated Pressure Gauge on the panel shows 3000psi, +/- 100 psi. If it does not, have a technician that has been trained on the maintenance of the MRS III adjust the regulator, per 16.11.

5.4. Place the SEA in the cylinder holder.

5.5. Connect the SEA to the fill hose, by placing the fill adapter (PRS21) into the fill port and rotating the knob clockwise until the O-ring is fully seated. (figure 4)

**!** 5.5.1. CAUTION-DO NOT USE A WRENCH OR PLIERS TO TIGHTEN!!!

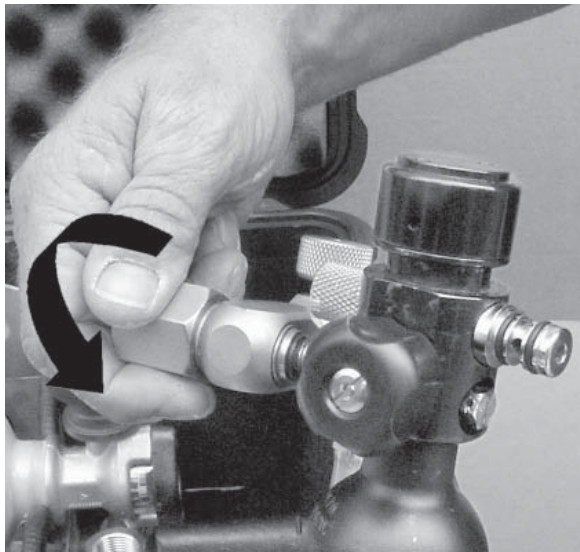

figure 4

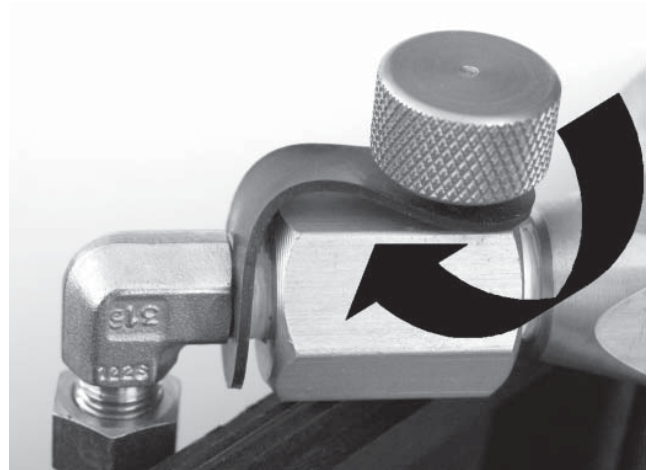

figure 5

5.6. If the fitting leaks, remove from the SEA and inspect threads and O-ring for damage. Replace or repair parts as needed.

5.7. Bleeder valve (712) should be closed (figure 5).

5.8. Slowly open the panel mounted valve (YVA3010A), counterclockwise, that corresponds to the fill hose(s) used (figure 6). There is no need to open any valve on the SEA.

5.9. Watch the SEA fill pressure gauge (CAG1). Fill the cylinder at a rate not to exceed 500psi per minute (figure 7).

5.10. After the cylinder reaches 3000psi +/- 100psi, close the fill valve (YVA3010A). Open the bleeder valve (712) on the fill hose used to vent the pressure from the fill lines.

5.11. Disconnect the fill hose from the SEA, by rotating the fill adapter (PRS21) counterclockwise.

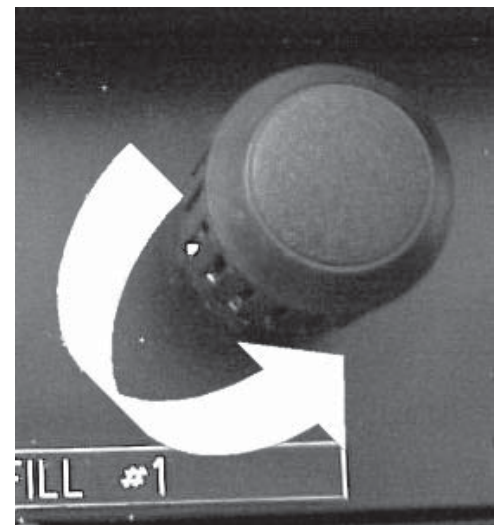

figure 6

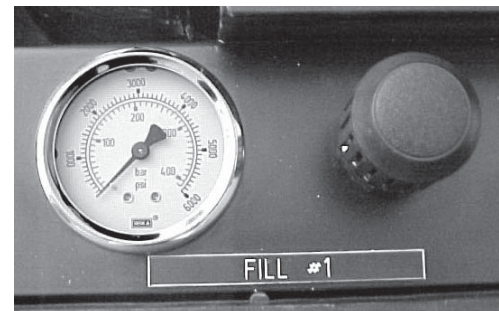

figure 7

## 6.0 REFILLING SUPPLY CYLINDERS:

6.1. Verify that the cylinders (CYL1) are within 5 years of the last hydrostatic test. Check the dated sticker placed prominently on each cylinder (figure 2). There is also a sticker on the cylinder neck, visible without removing MRS top plate (figure 3).

6.2. Visually check the observable portion of the outside of the cylinders for damage. If any is found consult manual for acceptable/unacceptable conditions.



6.2.1. NOTE-THIS INSPECTION SHOULD CONFORM TO COMPRESSED GAS ASSOCIATION PAMPHLET C-6.2 VISUAL INSPECTION OF FIBER REINFORCED HIGH PRESSURE CYLINDERS (EXTERNAL INSPECTION ).

6.3. This unit may be filled from any source of air that meets or exceeds CGA Grade “D” standards at pressures up to and including 4500psi. The standard inlet fitting is a 4500psi or a 300 BAR DIN (DIN-F) SCUBA fitting (PRS6). For US users, adapter for CGA 347 fill connections are provided. (figure 8)

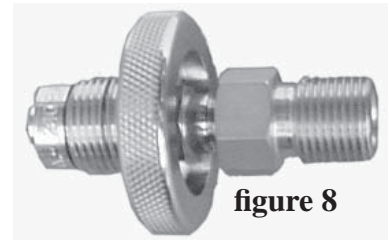

figure 8

6.4. Open the valves (VAL1) on both Supply Cylinders.

REFER TO FIGURE 3 (page 2) FOR A PICTURE OF THE VALVES

6.5. Remove rubber cap. (RCAP). (figure 9) Connect approved source of air to inlet fitting (DIN-F) (figure 10).

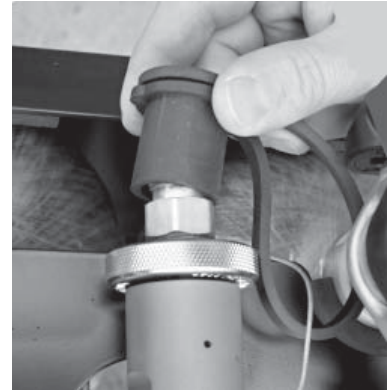

figure 9

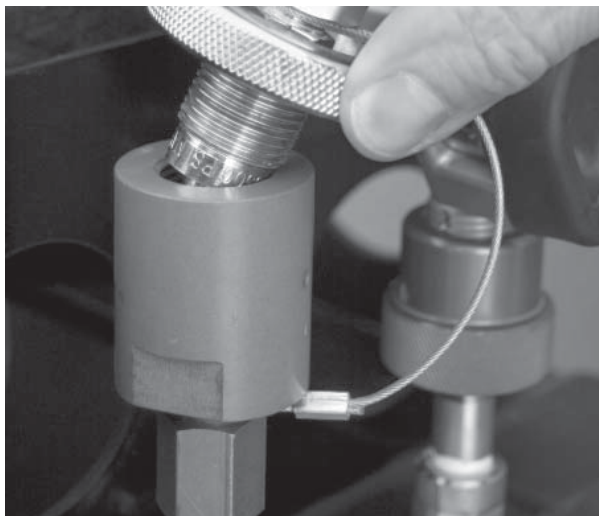

figure 10

6.6. Pressurize the system at a rate not to exceed 500psi per minute until it reaches the maximum pressure of the approved air supply, or 4500 psi, whichever is lower. (figure 11).

6.7. Close the supply cylinder valves (VAL1).

6.8. Close the valve from the approved air source and bleed the air from the fill connector.

6.9. Disconnect the approved air source from the fill connection (DIN-F). Replace protective rubber dust cap. (RCAP)

**7.0 AFTER FILLING IS COMPLETED:**

7.1. Verify that the supply cylinder valves (VAL1) are closed.



figure 11

7.2. Hold one of the fill hoses (HOS1) firmly and point the opening away from people (figure 12).



7.2.1. **WARNING** — AIM THE HOSE AWAY FROM YOURSELF AND FROM ANY OTHER PERSONNEL. HIGH PRESSURE AIR COMING INTO CONTACT WITH THE SKIN IS DANGEROUS. ALSO, ESCAPING AIR CAN CAUSE A LOUD NOISE.

7.3. Slowly open the fill valve (YVA3010A) that corresponds to the fill hose you are holding to release all pressure.

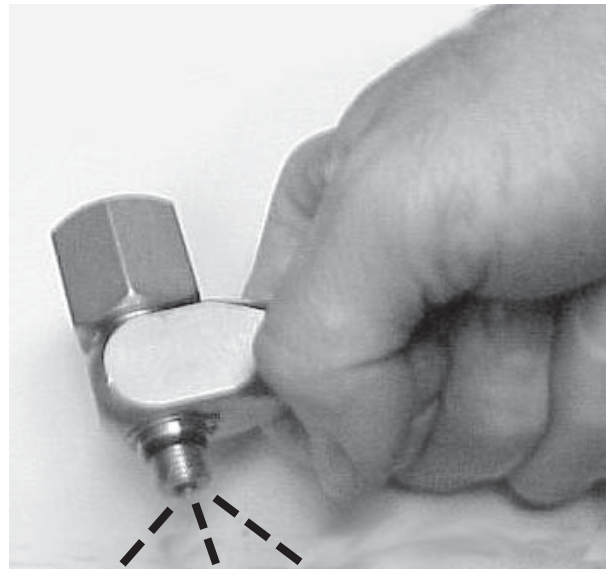

figure 12

7.4. Close all fill hose valves (YVA3010A) and bleeder valves (712).

7.5. Attach the fill hoses to the provided mounts (NUT2) (figure 13).

7.6. Close and securely latch the lid.

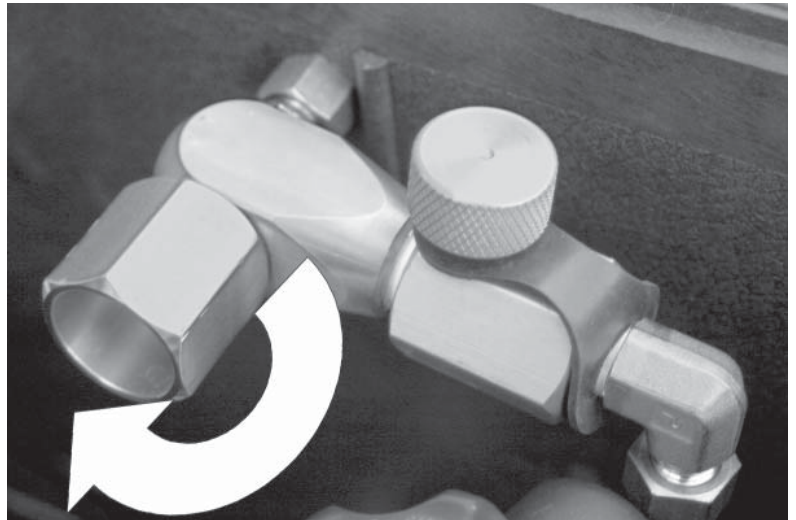

figure 13



## 8.0 WARNINGS:

8.1. This unit contains air under high pressure. Serious injury may result from misuse of this apparatus and the gas it contains.

8.2. Avoid blowing compressed gas at yourself or any other person.

8.3. Wear hearing protection.

8.4. Avoid standing over top of the unit when it is in use.

8.5. Have the gauges checked for accuracy every 18 months. They should be plus or minus 100 psi.

8.6. **Do not** overpressurize any compressed gas cylinder.

8.7. **Do not** fill a damaged cylinder.

8.8. **Do not** use this unit if the hoses are damaged.

8.9. **Do not** fill this unit if the supply cylinders have not had the proper hydrostatic testing done within FIVE years of today's date.

# MRS III MAINTENANCE

## Scheduled Service (1-year and 5-year)

### 9.0 AFTER 1 YEAR, AND EVERY YEAR THEREAFTER....

9.1. **PARTS REQUIRED:** 1-year overhaul kit ( Part Number MRSKIT1).

9.2. Open the Supply Cylinder valves (VAL1) and then slowly vent all air from the MRS III thru one of the fill hoses (HOS1).



9.2.1. **WARNING** — AIM THE HOSES AWAY FROM YOURSELF AND FROM ANY OTHER PERSONNEL. HIGH PRESSURE AIR COMING INTO CONTACT WITH THE SKIN IS DANGEROUS. ALSO, ESCAPING AIR CAN CAUSE A LOUD NOISE.

9.3. Replace all seals in the SEA fill adapter (PRS21). See figure 14. This consists of three O-rings, two (PRS21-3) and one (PRS21-6), and two back-up rings (PRS21-2).

9.3.1. The first O-ring (PRS21-6) is the one that makes the seal to the SEA. This is a normal wear item and can be replaced anytime. The tools required are an O-ring pick and the PRS21-8-3 (figure 15).

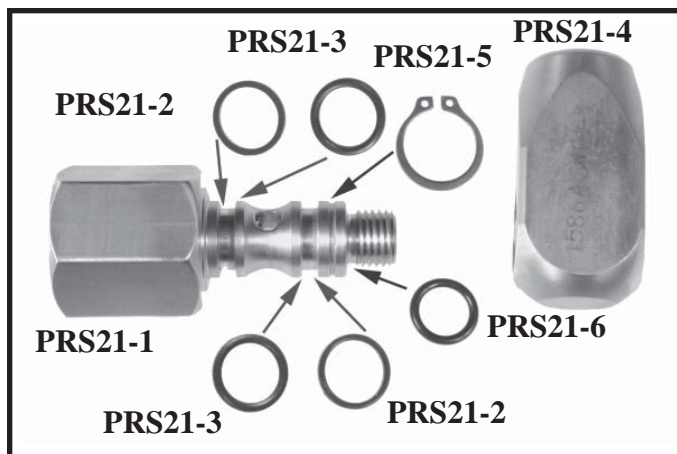

figure 14

9.4. To replace the other parts will require a set of external snap-ring pliers, an O-ring pick, the PRS21-8, and some non-toxic O-ring lubricant (Christo-lube).

9.5. To start, remove the visible O-ring (PRS21-6). Then using the snap-ring pliers remove the snap-ring (PRS21-5) and set it aside. Grasp the hex knob (PRS21-1) in one hand and hold the body (PRS21-4) in the other. Pull apart with a slight rotating motion of the hex knob. Use the O-ring pick to remove the O-rings and back-up rings.



9.5.1. **NOTE THE ORDER THAT THE PARTS ARE ON THE SHAFT: STARTING FROM THE HEX KNOB — BACK-UP RING (PRS21-2); O-RING (PRS21-3); O-RING (PRS21-3); BACK-UP RING (PRS21-2); SNAP-RING (PRS21-5); O-RING (PRS21-6).** See figure 14.

9.6. Clean the parts with a soft clean cloth to remove all of the old lubricant. Inspect parts for damage. If any is found replace the assembly.



figure 15

**NOTE:** PRS21-8 (103384) comes as a complete set; not available separately.

9.7. Lubricate the new seals generously with an approved non-toxic O-ring lubricant (Christo-lube), and slip the new seal on in the proper order.

9.7.1 It is recommended that you use tool set PRS21-8 (figure 15) to install the seals.



9.7.1.1 NOTE; INSTALL THE BACKUP RINGS (PRS21-2) WITH THE CONCAVE SIDE FACING THE O-RINGS (PRS21-3).

9.7.1.2 Install the seals and backup rings starting from the hex knob. If using the PRS21-8-1, first install backup ring (PRS21-2) and O-ring (PRS21-3) (figure 16).

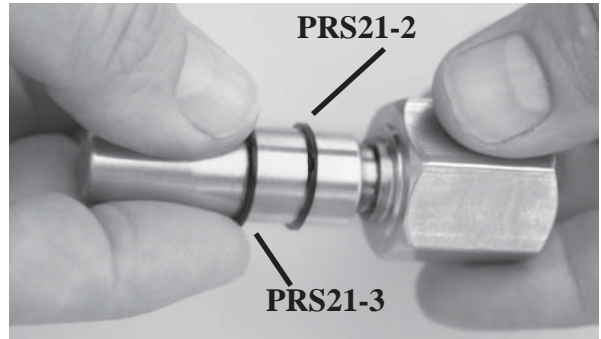

figure 16

9.7.1.3 Next, using PRS21-8-2, install O-ring (PRS21-3) and backup ring (PRS21-2) (figure 17).



figure 17

9.7.1.4 Using PRS21-8-3, install O-ring (PRS21-6) (figure 18).



figure 18

9.8 If tool set PRS21-8 is not available, install the seals with an O-ring pick, in the same order as 9.7.2, above. Carefully avoid stretching and nicking the seals while installing them.



9.8.1. CAUTION: INSTALL THE SEALS OVER THE THREADED END. DO NOT ATTEMPT TO STRETCH THEM OVER THE KNOB, AS DAMAGE TO THE SEALS WILL RESULT.

9.8.2 When completed, the spindle will look like in figure 19.

9.9. Once the seals are in place, lightly lubricate the inside of the body (PRS21-4) with Christo-lube, and slide the spindle into the body (figure 19). Once the spindle is in the body install the snap-ring (PRS21-5), using snap ring pliers. Wipe off any excess lubricant.

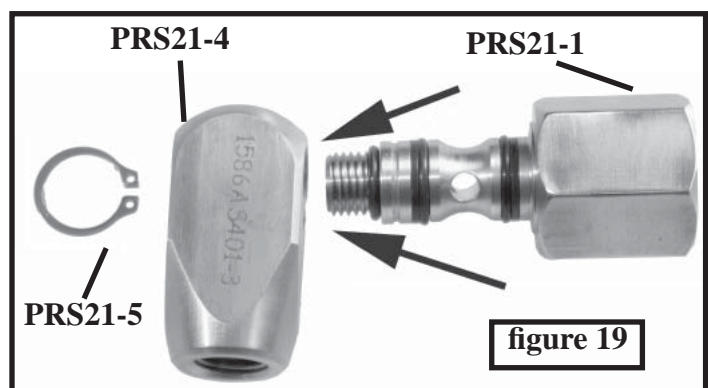

figure 19

## 10.0 REPLACING THE SEAT IN THE BLEEDER VALVE (712):

10.1. Unscrew the knob (712KNOB) and turn it over. The knob will pull through the bleeder keeper (59) by using a twisting motion. Using a sharp instrument get it under the edge of the white tip (712SSTIP) and lift it out of its hole.

10.2. If you cannot get out the white seat (712SSTIP) you may attempt to dig it out with an O-ring pick or simply replace the knob assembly (712KNOB). See figure 20.

10.3. Push 712SSTIP into hole. Reinstall in bleeder keeper.

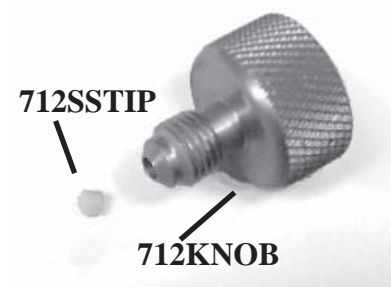

figure 20



figure 21



figure 22



*From this point on, it might be easier to perform maintenance with the system removed from the case. See section 13.0.*

## 11.0 REMOVING THE TOP PLATE:

11.1. There are six (6) screws that hold the top plate to the unit. Unscrew these (figure 21) and lift the plate (figure 22).



11.1.1. **WARNING-VERIFY THAT ALL PRESSURE HAS BEEN DRAINED FROM THE PLUMBING BEFORE PROCEEDING.**

11.2. Turn the top plate over, and inspect the foam padding (PAD1 and PAD2) for damage (figure 23). If foam is worn or damaged, replace.

11.3. Disconnect the cylinders (CYL1) from the fill adapters (835) (figure 24).

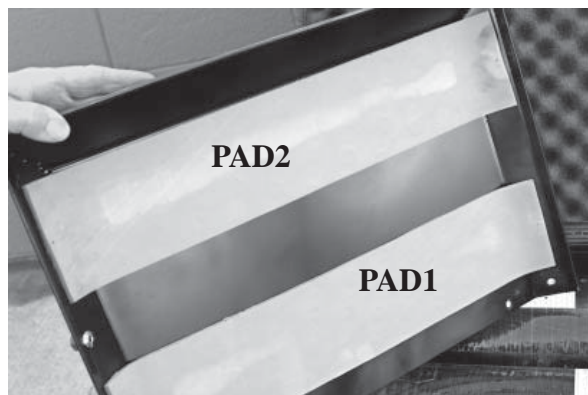

figure 23

**!** 11.3.1. WARNING: IF THESE DO NOT COME LOOSE WITH FIRM HAND STRENGTH, THERE MAY STILL BE AIR PRESSURE IN THE SYSTEM. VERIFY THAT ALL PRESSURE IS REMOVED BEFORE PROCEEDING. IF YOU CANNOT GET THIS LOOSE BY HAND YOU CAN USE SLIP JOINT PLIERS. DO NOT USE EXCESSIVE FORCE AS DAMAGE WILL RESULT.

11.4. Lift the cylinders (CYL1) out of the frame (FRM1) (figure 25). Inspect the padding (TRIM & PRS17) that the cylinders rest on. If it shows signs of damage or wear, replace with new.

11.4.1 PRS17 replacement requires altering by cutting it into two equal pieces. PRS17 makes the padding for both cylinders.

11.5. Have an authorized / properly trained technician visually inspect the cylinder inside and out to Compressed Gas Association Pamphlet C-6.2 standards (This is available direct from the CGA by calling 703-788-2700 ext.799 or via email from CustomerService@cganet.com)

11.5.1 Basic cylinder inspection criteria are listed in section 12.

11.6. Inspect all other components for obvious damage or excessive wear. If damage or wear is found, replace that component.

11.7. After the cylinders (CYL1) have been inspected it is time to reassemble the unit. Place a cylinder into the frame and line up the valve (VAL1) with the connection (835).



figure 24



figure 25

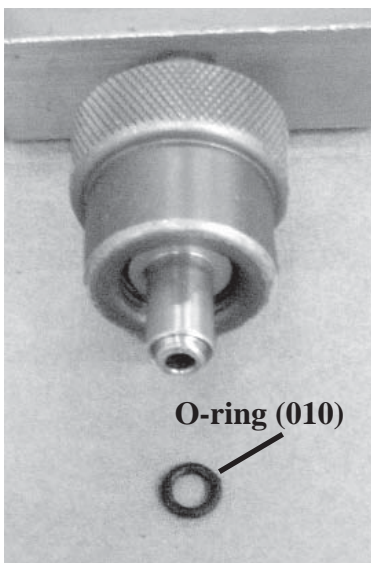

figure 26

**!** 11.7.1. Before connecting, verify that the O-ring (010) in the connection is in place and not damaged (figure 26). If damaged or missing, replace.

11.8. Thread the fill adapter (835) onto the cylinder valve (VAL1) by turning it clockwise until it pulls up tight. Snug this firmly by hand.

**!** 11.8.1. DO NOT USE TOOLS TO TIGHTEN THIS.

11.9. Repeat with the other cylinder.

11.9.1. When both cylinders are in place, reinstall the top plate/instruction sheet. Reinstall in case.

## 12.0 CYLINDER INSPECTION GUIDELINES

### 12.1 Cuts, Scuffs and Scratches

12.1.1 Usually these are confined to clear coat and are less than .005” deep. Flaws in clear coat alone are acceptable and repairable.

12.1.2 Flaws in clear coat can be repaired with any 5 minute epoxy, and then hydrostatically tested by a trained and authorized test facility before returning to service.

12.1.3 Rejectable flaws have visible fiber damage. If damage extends into the fibers replace the cylinder and destroy the damaged cylinder.

12.1.4 Heat or fire damage that causes discoloration or charring is cause for rejecting the cylinder.

### 12.2 Delamination

12.2.1 Delamination calls for rejecting the cylinder.

### 12.3 Impact

12.3.1 Look for fiber delamination; if delaminated, reject cylinder.

12.3.2 Transverse fiber breaks call for rejecting the cylinder.

12.3.3 Small impacts will show white spots without significant delamination. If no fiber breakage is noted and damage is less than 1/2” diameter and there is no dent, cylinder may be hydrostatically tested and returned to service.

### 12.4 Internal inspection (to be performed by trained and authorized inspection center only)

12.4.1. Check for cracks in the neck area. If cracks are present reject the cylinder.

12.4.2. Check cylinder walls for corrosion. If corrosion is present have an authorized test facility remove the corrosion and check for cylinder wall pitting damage.

12.4.2.1. If pitting exceeds the allowable limits reject the cylinder. Limits are not printed here as a properly trained inspector will have this data available and it is subject to change .

*If there is any question as to the integrity of the cylinder either replace it or return it to Breathing Air Systems (614-864-1235 or [service@breathingair.com](mailto:service@breathingair.com)) for evaluation.*

## 13.0 WHEN FURTHER MAINTENANCE IS SCHEDULED OR REQUIRED, REMOVE THE UNIT FROM THE CASE.

13.1. With the lid closed and latched, turn the MRS III over. Remove the four screws from the back of the case. (figure 27).

13.2. Turn case over, open lid, and lift the unit out of the case (figure 28).



13.2.1 Be sure to support the plumbing with your hand as you lift the frame.

**14.0 GAUGE CALIBRATION:** The gauges (GAG1) on this unit are of a sealed design. You have to verify the accuracy. Gauge calibration in accordance with local instructions. Acceptable variance is 100psi in the center of the range (1500psi to 4500psi), or  $\pm 200$ psi at the bottom or top of range. If not within these limits they will have to be replaced.

14.1. To verify the calibration on these gauges (GAG1), they may be removed from the system, or they can be checked in the system if the calibration technician has the proper connectors.

**⚠** 1. CAUTION: DO NOT CONTAMINATE THE MRS III BY USING CALIBRATION APPARATUS THAT WILL PUT OIL INTO THE SYSTEM.

14.1.2 To calibrate the gauges without removing them from the unit will require you make 3 separate connections.



**figure 27**

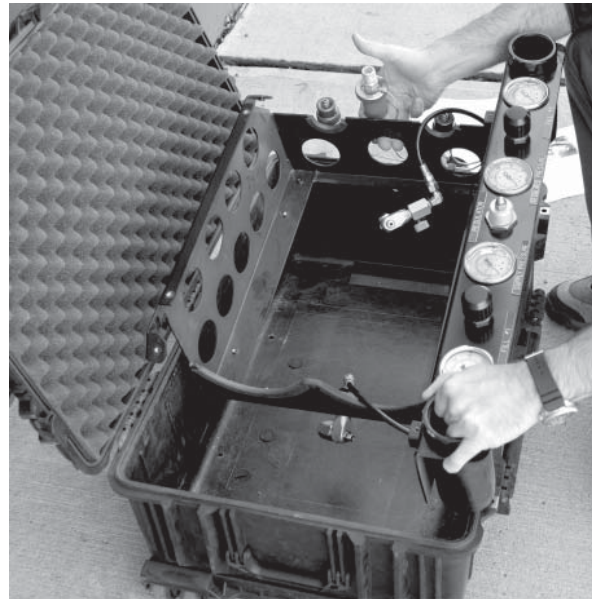
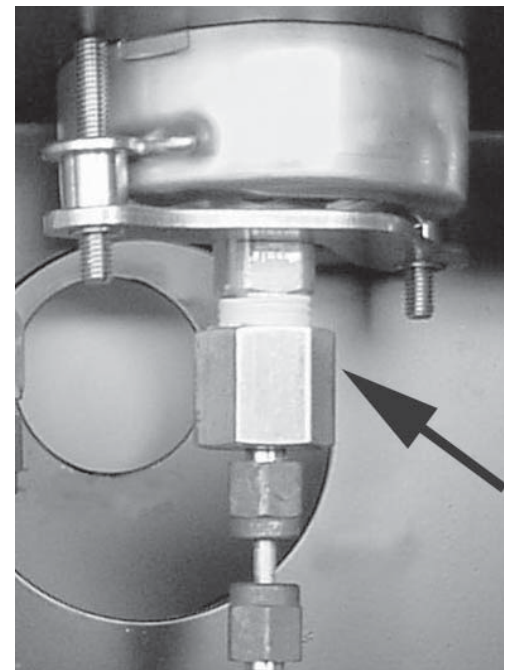

**figure 28**

14.1.3 To test the supply pressure gauge you will need to connect your master gauge to the refill port with a tee. There is a check valve on this port so the air supply must come from the refill port and test gauge to the supply pressure gauge. This will allow you to test the supply pressure gauge.

14.1.4 To test the regulated pressure gauges and the fill pressure gauges you can connect your test gauge to one of the fill lines (removing the PRS-21 for access to a 1/4" NPT). Use air from the supply cylinders or supply air thru the refill port to pressurize these gauges. This will allow you to check the fill pressure gauge on the side that you are connected on and the regulated pressure gauge. Remove the test gauge; reinstall the PRS21 and repeat on the other side for the other fill pressure gauge.

14.2. If the gauges (GAG1) need to be removed simply disconnect the tubing fitting (PRS10) from the back of the gauge using a 7/16" wrench (figure 29). Always use a 3/4" backup wrench. Then loosen the gauge bracket with a small straight screwdriver. Once loose the bracket will slip out of the gauge and the gauge will lift out of the panel.



**figure 29**

14.3. The rear connection on the gauge is ¼” MNPT and will have a standard industrial 1/8” tube high-pressure compression fitting (PRS10). The calibration technician may connect either to the compression fitting or to the ¼” MNPT.

14.4. If the compression fitting is removed it must be reinstalled with PTFE (Teflon) tape. Reinstall the gauge by reversing the removal procedure. The compression fitting should be tightened by hand and then snugged firmly with a 7/16” wrench (see figure 29).

14.5. When the inspection and gauge calibration is done, reinstall the frame (FRM1) into the case (1650). This is easily done by placing the case on a table and lifting the frame into the case. Close the lid, and turn unit over. Insert the four screws (BLT3), and tighten.

14.5.1 If you have trouble aligning the screw holes, turn the unit right-side up and open the lid. Then slide the case partway off of the table and reach under the case and start two of the screws (BLT3). Run these in snug but not tight. Turn the case around so that you can start the other two screws.

14.6. Once all 4 screws are started, tighten all of them securely by hand with #3 Phillips screwdriver.

14.7. Install cylinder per reverse of 11.7 through 11.9.1. Reinstall top plate per reverse of 11.1.

14.8. The MRS III is now ready to pressure test. Close the supply cylinder valves (VAL1). Attach the approved source of CGA grade “D” Breathing Air to the refill port (DIN-F) and slowly pressurize to 1000psi. Close the valve on the refill source. Allow the unit to stand for 5 minutes. After 5 minutes check for pressure loss. If there was pressure loss repair the leaks and start again.

14.9. If there was no pressure loss, you may pressurize to 4500psi (or to the limit of your supply, whichever is lower). Once the plumbing is at full pressure, hold it there for 5 minutes and check for pressure loss. When the pressure will hold for 5 minutes with no leaks it is time to recharge the supply cylinders, following the procedure from section 6. Return the unit to service.

## **15.0 AFTER 5 YEARS OF SERVICE AND EVERY 5 YEARS THEREAFTER....**

15.1. Perform all of the 1-year maintenance. While unit is removed from case, proceed with 5-year maintenance.

15.2. While the cylinders are out of the unit they must to be hydrostatically tested according to the DOT standard. This is done by sending them out to an authorized DOT testing facility, or by returning them to Breathing Air Systems (contact Breathing Air Systems at 800-937-2479 or 614-864-1235, or via e-mail at [service@breathingair.com](mailto:service@breathingair.com) ).



5.2.1. NOTE: AS OF OCTOBER 2000 THE CARBON FIBER WRAPPED CYLINDERS (CYL1) USED IN THE MRS III HAVE A MAXIMUM SERVICE LIFE OF 15 YEARS.

15.2.2. Cylinders (CYL1) are available as replacement parts.

15.3. You will need to rebuild the fill valves (YVA3010A), supply cylinder valves (VAL1) and the preset regulator (1120).

15.4. After the 5-Year Maintenance is completed return the unit to service.

15.5. Fill valve (YVA3010A).

15.5.1. With valve open, remove the plastic center cap (YVA-KNOB-2) from the valve knob (YVAKNOB-1). Remove the nut (YVANUT) that holds the knob; using notched screwdriver from your SEA Tool Kit (PN9-47448). See figure 30 for parts breakdown.

 15.1.1.1. CAUTION: THERE IS LIGHT SPRING TENSION ON THIS NUT.

15.5.2. Lift off the knob (YVAKNOB-1) and inspect the center hole for damage. The hole should be square; if it shows any rounding you must replace the knob. The knob is a standard replacement item and is included in MRSKIT2.

15.5.3. This exposes a hex-shaped bonnet nut (YVA-BONNET). Remove this with a 11/16" wrench or socket. The valve stem (YVASTEM) will likely come out with this. Push the valve stem out and set both parts aside.

15.5.4. The seat (YVAKIT-1) is inside the valve body and can be removed by taking the valve stem and placing over the tang of the seat and using the valve knob (YVAKNOB-1) to turn it counterclockwise, until it is loose from the threads. Lift it out.

15.5.5. Clean the body to remove any dust. The valve overhaul kit (YVAKIT) will contain a new seat, copper gasket, packing washers, and knob. The stem (YVASTEM), spring (YVASPRING), and nut (YVANUT) are also available as replacement parts, but are not normal wear items and typically are only replaced if damaged or lost.

15.5.6. The packing consists of two white plastic washers, one thick (YVAKIT-4) and one thin (YVAKIT-3). Use the O-ring pick to pull the old ones out of the valve bonnet nut (YVABONNET). Clean the bonnet with a soft cloth to remove the residue of the worn packing. To install the new packing, place the thick washer into the bonnet followed by the thin washer.

*\* YVAKNOB consists of YVAKNOB-1 and YVAKNOB-2. Not available as separate parts.*

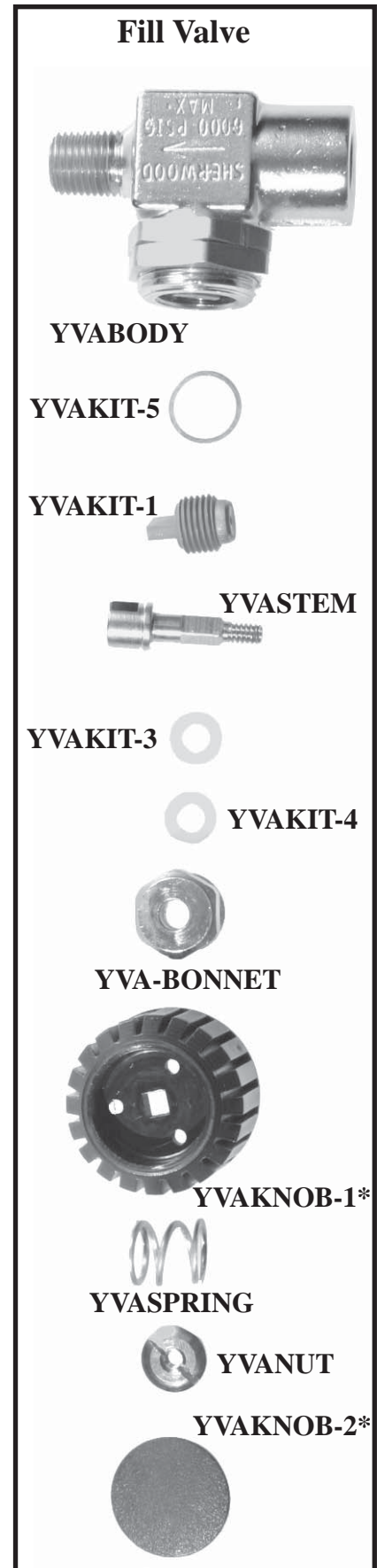

figure 30

15.5.7. The only other replaceable part in the valve body is the copper gasket (YVAKIT-5) that seals the bonnet nut to the body. Use the O-ring pick to lift this out. Use caution: a scratch on the body will cause leakage and require body replacement.

15.5.8. To replace the seat (YVAKIT-1) use the stem (YVASTEM) to screw the new seat assembly into the valve body (YVABODY). Screw this down against the seat but do not use the knob to tighten it. Put the copper gasket (YVAKIT-2) in place at the base of the body threads, and place the stem on the tang of the seat assembly. Slip the bonnet (YVABONNET) down the stem and then screw it into the body. Tighten with the wrench or socket, to 20-30 foot pounds.

15.5.9. Place the knob (1389-2D) on the square of the stem, place the spring (YVASPRING) and then the nut (YVANUT) onto the stem. Use notched screwdriver (9-47448) from SEA toolkit to tighten the nut onto the stem. Reinstall the plastic center cap. (1389-4)

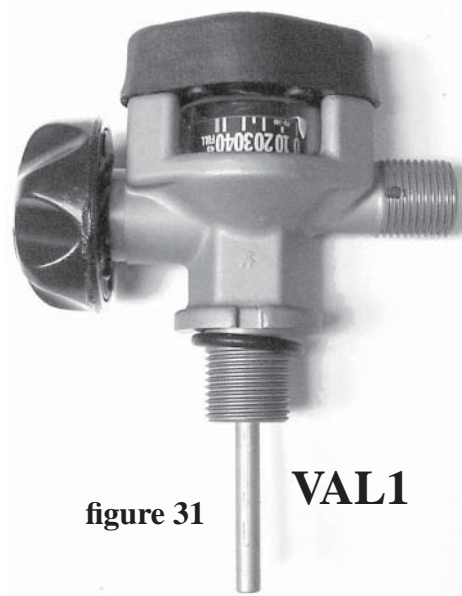

figure 31 VAL1

## 15.6. SUPPLY CYLINDER VALVES (VAL1).

15.6.1. The supply cylinder valves (figure 31) are very similar to the fill valves, along with some additional parts.

15.6.2. There are three additional sets of parts. The first is the safety burst disc assembly (6509-72), a normal replacement part. Second are the valve lock parts; these are not normal replacement parts. The third is the gauge.



figure 32

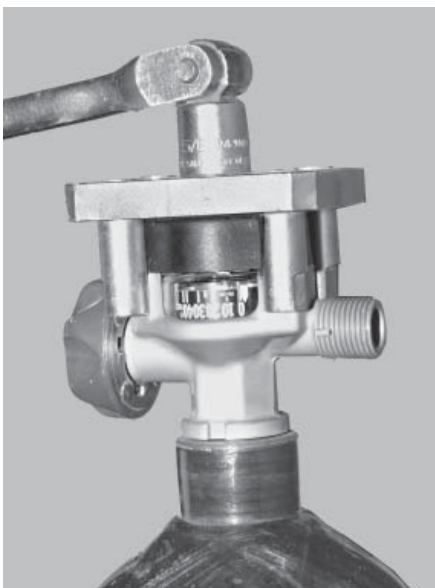

figure 33

15.6.3. Supply Cylinder Valve (VAL1) rebuild procedures.

15.6.3.1. Remove supply cylinder (CYL1) from MRS III.

**!** 15.6.3.1.1. WARNING! ASSURE THAT THERE IS NO PRESSURE INSIDE THE CYLINDER. DO THIS BY CHECKING THE GAUGE LOCATED ON THE CYLINDER VALVE AND BY SLOWLY OPENING THE VALVE.

15.6.3.2. The valve (VAL1) can be rebuilt either with it in the cylinder or with it removed from the cylinder. It is preferable to have the valve removed from the cylinder, as this allows easier handling and better cleaning.

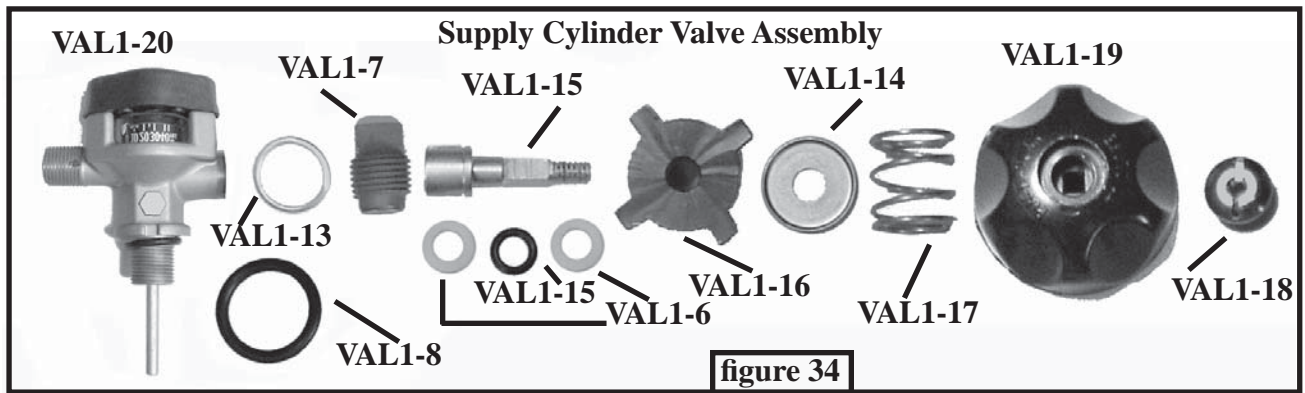

15.6.3.2.1. NOTE! DO ALL WORK ON A CLEAN WORK SURFACE AS IT IS IMPORTANT THAT THIS VALVE BE KEPT CLEAN.



15.6.3.2.2. NOTE! REMOVING AND REINSTALLING THE VALVE INTO THE CYLINDER REQUIRES SPECIAL TOOLS AND TRAINING, SO THIS SHOULD ONLY BE DONE BY TECHNICIANS TRAINED IN CYLINDER INSPECTION OR TESTING.



**100786**  
figure 35

15.6.3.3 When removing the valve, it is recommend that you use valve tool VAL1-10. (figures 32 and 33)

15.6.3.4. Using notched screwdriver #9-47448 from the SEA tool kit, remove the nut (VAL1-18) that holds the knob (VAL1-19) on. Then lift the knob off. Lay aside (figure 34).

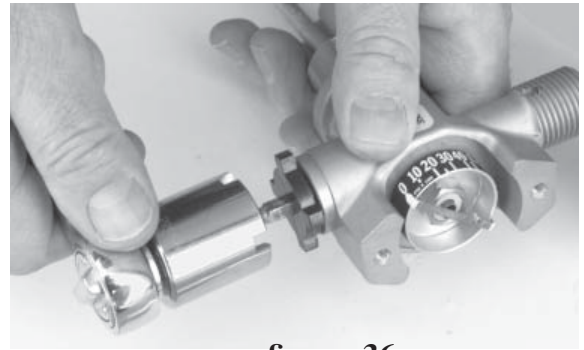

figure 36



15.6.3.4.1. CAUTION! THERE IS SLIGHT SPRING TENSION HOLDING THIS NUT. USE CAUTION WHEN REMOVING.

15.6.3.5. This will expose the bonnet (VAL1-16) nut. Remove the nut using a valve nut tool VAL1-12 (figures 35 and 36), or if this tool is not available use a 12" adjustable wrench endwise (figure 37). Lift the nut off and push the stem out of the nut. Use the stem (and the knob if needed) to remove valve seat assembly.

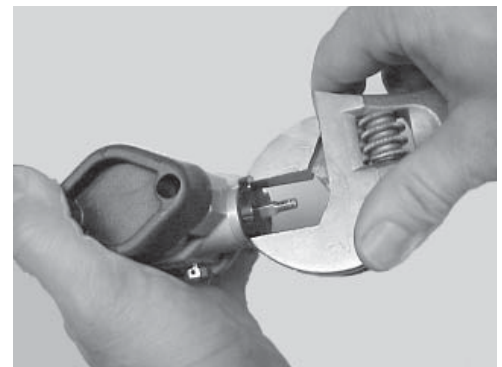

figure 37

15.6.3.6. Using an O-ring tool remove the packing washers from inside the bonnet nut. (VAL1-16).

15.6.3.7. Remove the safety disc plug (VAL1-9) by using a 3/8" wrench or socket and turning counterclockwise until it is out (figure 38). Reinstallation torque is 70-80 inch-pounds (Non-critical, for reference only). If the disc does not come out with the plug, then turn the valve so that the opening is down and then tap it against the palm of your hand. If this fails to dislodge the disc, use a sharp O-ring tool to push it thru the center of the disc and pull the disc out.

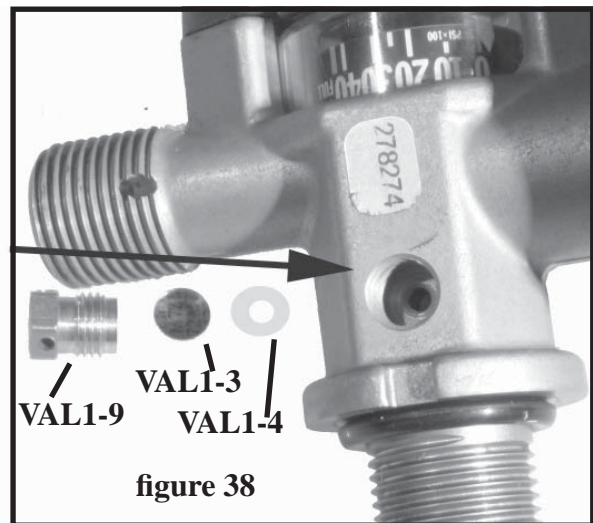

figure 38

15.6.3.7.1. CAUTION! BE CAREFUL NOT TO DAMAGE THE SEALING SURFACE OF THE VALVE BODY. DAMAGE MAY REQUIRE THAT THE VALVE BE REPLACED.



15.6.3.8. Remove the gasket (VAL1-4) from under the disc.

15.6.4. The gauge requires a special gauge tool VAL1-11 (figure 39) to service. The rubber bumper is removed using a square drive screwdriver. Under this bumper is a spring washer and the gauge cover; lift these off and set aside. Using the gauge tool VAL1-11, remove the gauge by screwing it counter clockwise (figure 40).



100787 figure 39



figure 40

15.6.4.1. Once the gauge is out (figure 41), remove the O-ring and back up ring from the stem, and replace with the new parts (VAL1-2 O-ring; VAL1-1 back up ring) and reverse the procedure above to reassemble.

CAUTION: DO NOT USE POWER TOOLS TO REMOVE OR INSTALL SQUARE DRIVE SCREWS (VAL1-26).

15.6.4.2. The valve is now completely disassembled. Clean the valve by one of the following methods: wipe with a clean, lint-free cloth, or use a soft bristle brush and blow with grade D air.

CAUTION: DO NOT CLEAN THE GAUGE FACE WITH ANY LIQUID AS THIS WILL DESTROY THE NUMBERING.. IF THE GAUGE FACE IS DIRTY, REPLACE THE GAUGE.

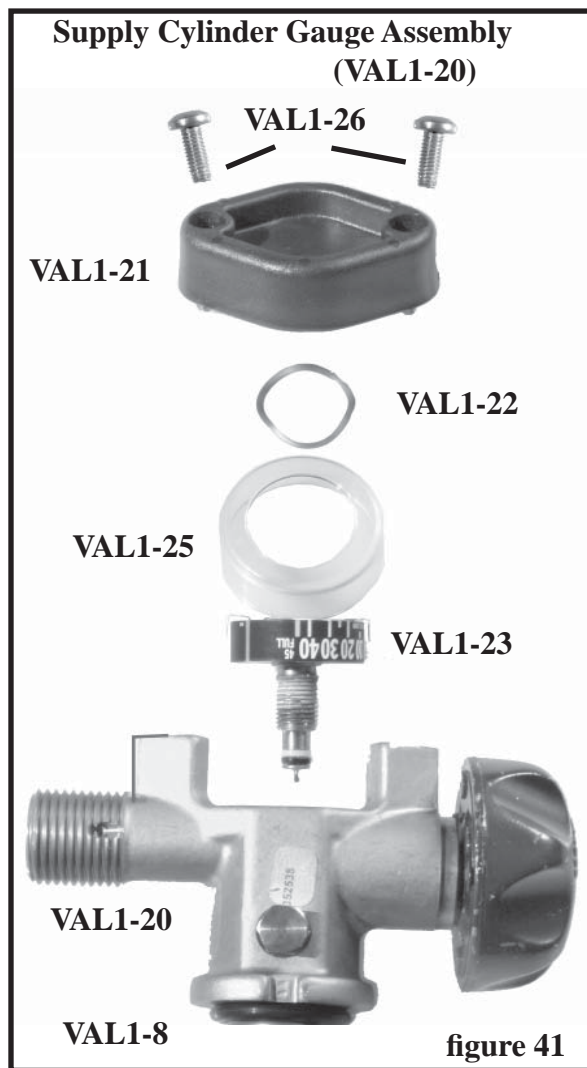

15.6.4.3. If the valve is still in the cylinder the only method you can use is to wipe with a lint free cloth (damp or dry either is fine), or a soft bristle brush. Use a source of Grade D breathing air to blow out all internal passages.

15.6.4.4. Assemble in the reverse order of disassembly. Use Christo-lube on all O-rings.

15.6.4.5. Replace neck valve O-ring VAL1-8. Lubricate first with Christo-lube.

15.6.4.6. Reinstall the valve into the cylinder if it was removed, using valve tool VAL1-10 (figure 32). This has a non-critical torque of 45 foot pounds.

15.6.5 If possible, test the valve by pressurizing the cylinder to 1000psi and checking for air leaks. After the valve is leak free at 1000psi then pressurize to 4500psi and check for leaks. Otherwise, reinstall into system and test. After it is leak free at 4500psi, reinstall into the MRS III and return to service.

## 16.0 MRS III Regulator (1120)

16.1. In order to rebuild the preset regulator (1120) it first must be removed from the panel. To do this the plumbing must initially be drained of all air, and the unit removed from the case.

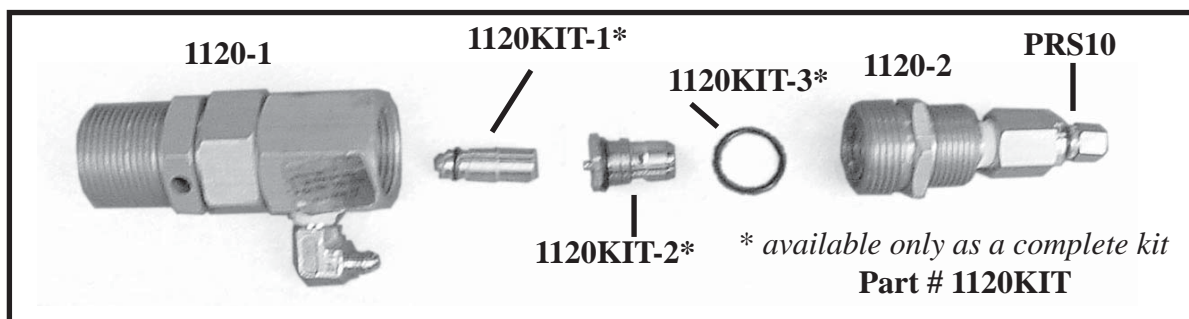

Regulator Assembly  
figure 42

16.1.1. Place the unit face down on a clean work surface that has been covered with a pad or towel (to protect the unit from scratches on the face). Note the position of the regulator and plumbing.

16.1.2. Disconnect the two compression connections (PRS8 and MRS2) from the regulator's inlet and outlet fittings (figure 43). Use a 7/16" size wrench.

16.1.3. Turn the unit face up on the work surface.

16.1.4. Remove the acorn nut (MRS13) on the adjusting screw with a 9/16" wrench. Using a 3/16" Allen wrench rotate the adjusting screw counterclockwise until all spring pressure is released from it (figure 44). It is possible and acceptable to completely remove this screw from the regulator.

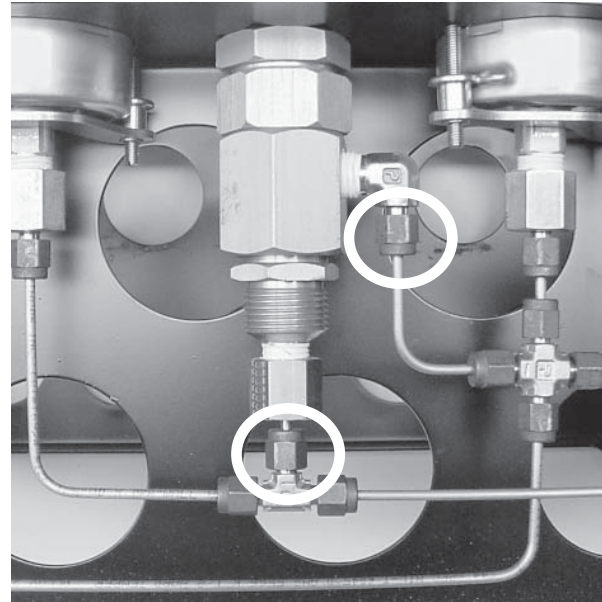

figure 43

16.1.5. Using a large adjustable wrench remove the mounting nut (NUT1) by turning counterclockwise.

16.1.6. Lower the regulator out of the hole in the control panel. Use caution on tubing below.

16.2 Once the regulator has been removed, place the system aside and proceed with the regulator rebuild.



16.2.1. NOTE-THE REGULATOR (1120) MUST BE KEPT VERY CLEAN INSIDE. IT IS IMPORTANT TO WORK ONLY IN A CLEAN ENVIRONMENT.

16.3. The regulator can be disassembled using either two wrenches, or one wrench and a vise. Hold the spring cap of the regulator (1120-1). Turn the smaller hex (1120-2) — the piece with the smaller of the two male threads visible — counterclockwise until it is separated.

16.4. Take the main body and turn it so that the end you just opened is down. Tap it gently on your hand or the padded bench to get the piston (1120KIT-1) to drop out. Set both aside.

16.5. Take the body (1120KIT2) that you screwed out of

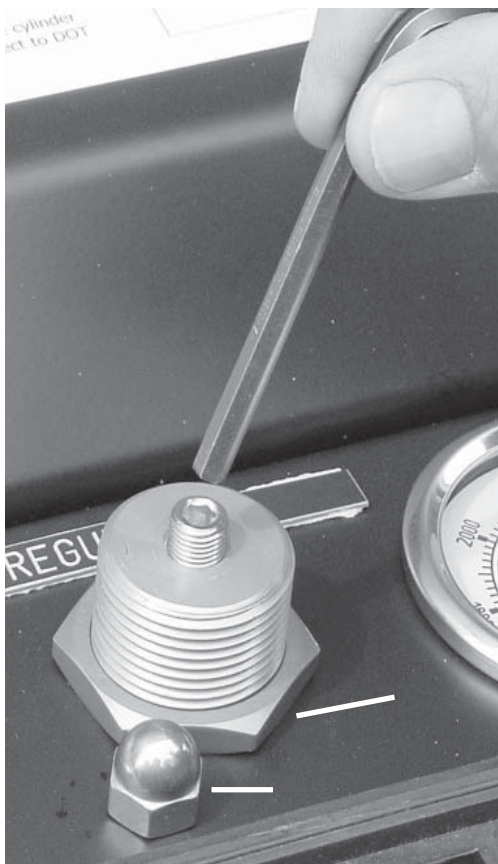
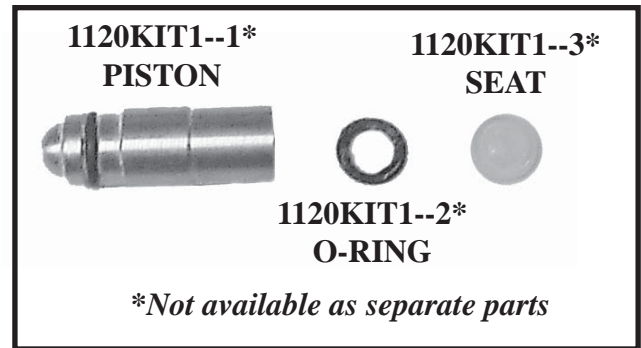

figure 44

the spring cap and turn it so that the inside portion is facing up. You will see an O-ring (1120KIT-3) and a smaller hex opening(1120KIT-2). Using an O-ring tool remove the O-ring and set it aside. Use a 5/8 socket wrench to remove the hex valve cartridge (1120KIT-2). Set this aside. (see figure 42).

16.5.1. Part # 1120KIT1 has a seat and O-ring in its flat end. These are normally factory installed. If they are loose see figure 45 for assembly.



**1120KIT-1 DETAIL**  
**figure 45**

- 16.6. Clean all parts with a clean soft lint-free cloth. If there is dirt that does not come off with a cloth, you can wash the parts in a mild detergent (no perfume) and hot water, rinsing with clear hot water, then blow dry or allow to air dry. Ultrasonic cleaning is acceptable using a mild detergent solution and a clear water rinse.
- 16.7. Once the parts have been cleaned and dried, reassemble in reverse order using the new parts provided in the 5-year maintenance kit for regulator repair. Lubricate all moving parts with an approved O-ring lubricant (Christo-lube).
- 16.8. Tighten all parts snug with a wrench but avoid using excessive force.
- 16.9. Reinstall regulator into panel, using the reverse order of 16.1. Do not reinstall acorn nut.
- 16.10. Reinstall cylinders per 11.6 through 11.9.
- 16.11. Test plumbing for leaks per 14.8. Fill system to 4500psi, and adjust regulator with the following procedures:
- 16.11.1. Loosen set screw with a 3/16" Allen wrench.
  - 16.11.2 Open cylinder (CYL1) to pressurize inlet side of regulator, with fill valves closed. Use caution to not overpressurize gauge.
  - 16.11.3 Turn the set screw clockwise until the regulated pressure reads 3000psi. Hold one fill hose, and open and close the fill valve.
  - 16.11.4. Verify that the regulated pressure gauge reads 3000psi. If it does not, turn the set screw clockwise to increase; counterclockwise to decrease.
  - 16.11.5. Open/release the fill valve; install the acorn nut, and verify the pressure reading.
- 16.12. Once plumbing is leak free and regulator is adjusted, reinstall the unit into the case, refill with air and return to service.

## 17.0 MRS III Case (1650)

17.1 The case for the MRS III is Pelican Products #1650.

17.1.1 This case is covered by “The Pelican Unconditional Lifetime Guarantee of Excellence”. If the case is damaged or broken contact Pelican Products at 800-473-5422 in the US except California or at 310-326-3311 outside of the US; you can also contact them via fax at 310-326-3311 inside the US, 310-325-5740 outside the US. In Canada you can contact Pelican Products Canada at 780-481-6076 or via fax at 780-481-9586. You can also contact them at [www.pelican.com](http://www.pelican.com).

17.1.2 When returning the case for repair or replacement you will need to remove all equipment from the case including the hose mounts and the manual.

17.1.2.1 The case will be returned without any mounting holes, it will be your responsibility to drill the replacement case for the equipment. You may instead return the entire unit to Breathing Air Systems to handle the Pelican Warranty. Please note there will be a charge for labor after the initial 1 year warranty.



**figure 47** Push handle latch (white arrow) to the right, to raise or lower the case handle.



**figure 46** To open and close the MRS III case, note that there are seven latches; three in front, and two on each side.

**figure 48**  
Carrying handles on the top and side should be pushed flat against the case when wheeling or packing.



**figure 49** Using the handle and wheels to transport the MRS III.

# TROUBLE SHOOTING CHART

## FOR THE MRS III

PROBLEM	ACTION
<b>Leaks at connection to EBS.</b>	O-ring at fill connection is damaged or missing. Replace O-ring.  Contaminants on O-ring or sealing surface of fill port of EBS. Clean and inspect, repair if damage is present.
<b>Leaks at fill connector swivel</b>	Rebuild fill connector swivel joint.  Replace fill connector.
<b>Leaks at inline bleeder</b>	Tighten valve knob by hand. If valve is tight, replace valve seat.  Replace inline bleeder.
<b>Leaks at hose</b>	Check fittings to make sure they are tight. If the leak is not from the fitting where it meets another fitting, replace hose.
<b>Fill hose shows damage</b>	Replace fill hose.
<b>Fill hose fails to shut-off when valve is closed</b>	Rebuild valve.  Replace valve.
<b>Leak from fill valve</b>	Rebuild valve.  Replace valve.
<b>Fill valve knob turns but does not operate valve</b>	Replace valve knob. Rebuild valve.
<b>Fill pressure exceeds 3000 psi</b>	Verify the accuracy of the gauges.  Have an authorized and trained technician adjust the regulator. If an adjustment does not correct the problem, rebuild the regulator and adjust.
<b>Regulator leaks</b>	Verify that it is the regulator that is leaking and not a fitting. If it is a fitting see "Leak at Fittings".  Rebuild regulator.  Replace regulator

<b>Leak at fitting</b>	<p>Inspect fitting for damage, if damaged replace fitting.</p> <p>If fitting is loose: Pipe Thread fittings must be removed, have the Teflon tape replaced and reinstall with the same orientation as before.</p> <p>Compression and Flare fittings can be tightened without need to remove them. NOTE: Compression and Flare fittings do not use Teflon tape.</p> <p>Replace fitting.</p>
<b>Gauge reading incorrect</b>	<p>Have calibration technician verify accuracy of gauge. Gauges are not adjustable. Reading should be plus or minus 100psi in the center of the range.</p> <p>Replace gauge.</p>
<b>Leak at gauge</b>	<p>Check fittings for tightness.</p> <p>Replace gauge.</p>
<b>MRS leaks out the refill port</b>	<p>Rebuild inlet check valve.</p>
<b>Leak at connection to supply cylinder</b>	<p>Check the connection to make sure it is hand tight.</p> <p>Replace O-ring in connector.</p> <p>Inspect cylinder valve and connector for damage, replace if damaged.</p>
<b>Leak at supply cylinder to valve</b>	<p>Remove valve replace O-ring and reinstall valve.</p> <p>Inspect cylinder and valve for damage. Replace if damaged.</p>
<b>Leaking supply cylinder valve</b>	<p>Rebuild valve.</p>
<b>Supply cylinders have air pressure showing on gauge in valve but no pressure showing on supply pressure gauge</b>	<p>Verify that both supply cylinder valves are fully opened.</p> <p>Rebuild valves if there is air in the cylinders.</p> <p>Replace supply cylinder valve gauges if there is no pressure in the cylinders, but the gauge reads pressure.</p>
<b>Supply cylinder fails hydrostatic test</b>	<p>Replace supply cylinder.</p>

<b>Supply cylinder is damaged</b>	Inspect per CGA Pamphlet C-6.2. Replace if damage exceeds allowable limits.
<b>MRS III case is damaged</b>	Replace case.
<b>MRS III metal frame is damaged</b>	Inspect metal frame:  If damage is minor then the metal can be straightened using standard shop practices and hand tools.  If damage is major replace MRS-III.
<b>MRS III exceeds 15 years from manufacture date</b>	Contact Breathing Air Systems to see if the supply cylinders life has been extended beyond 15 years. If not, replace the supply cylinders.

# Illustrated Parts Breakdown

## Mobile Refill System III (100701)

---

---

### FRONT OF UNIT

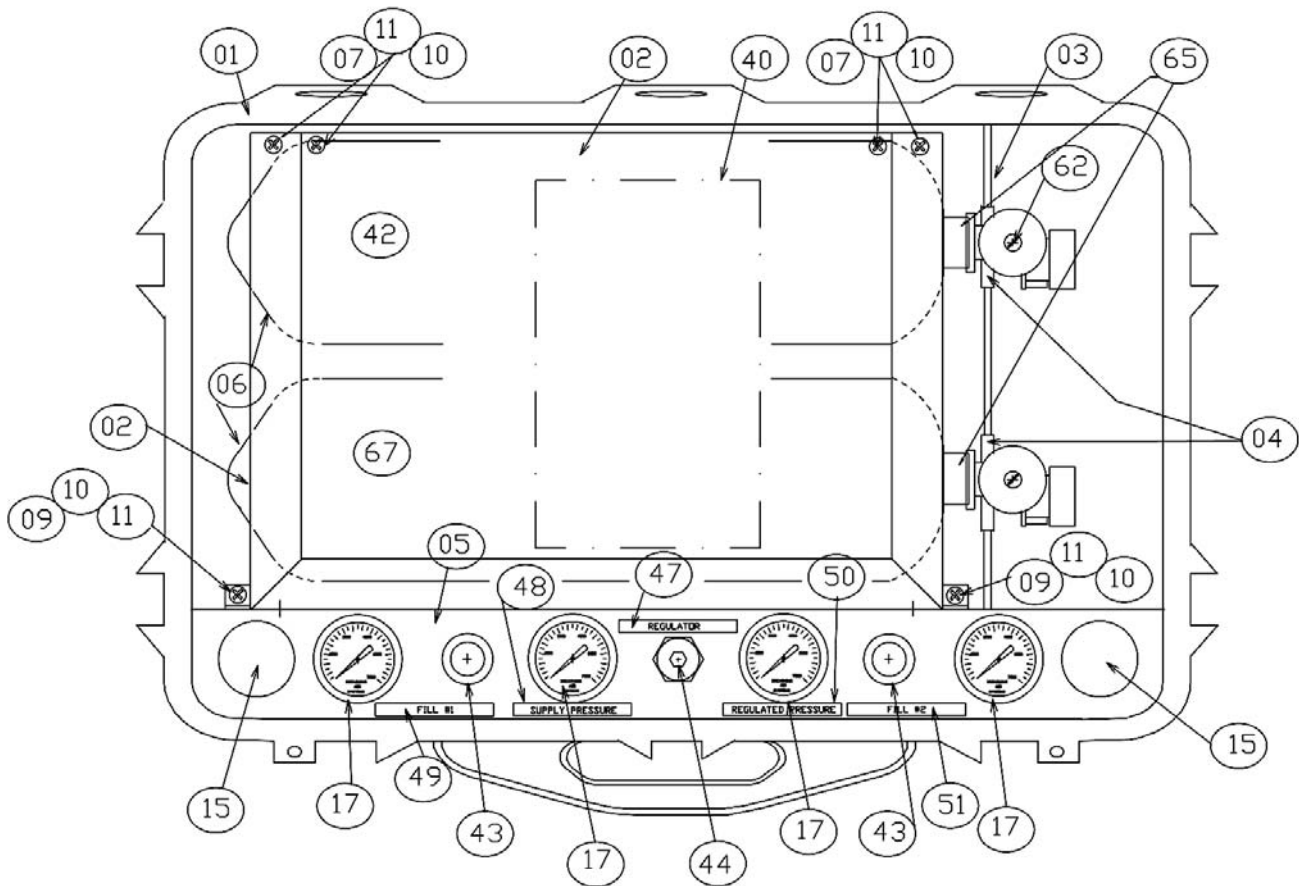

# SIDE VIEW

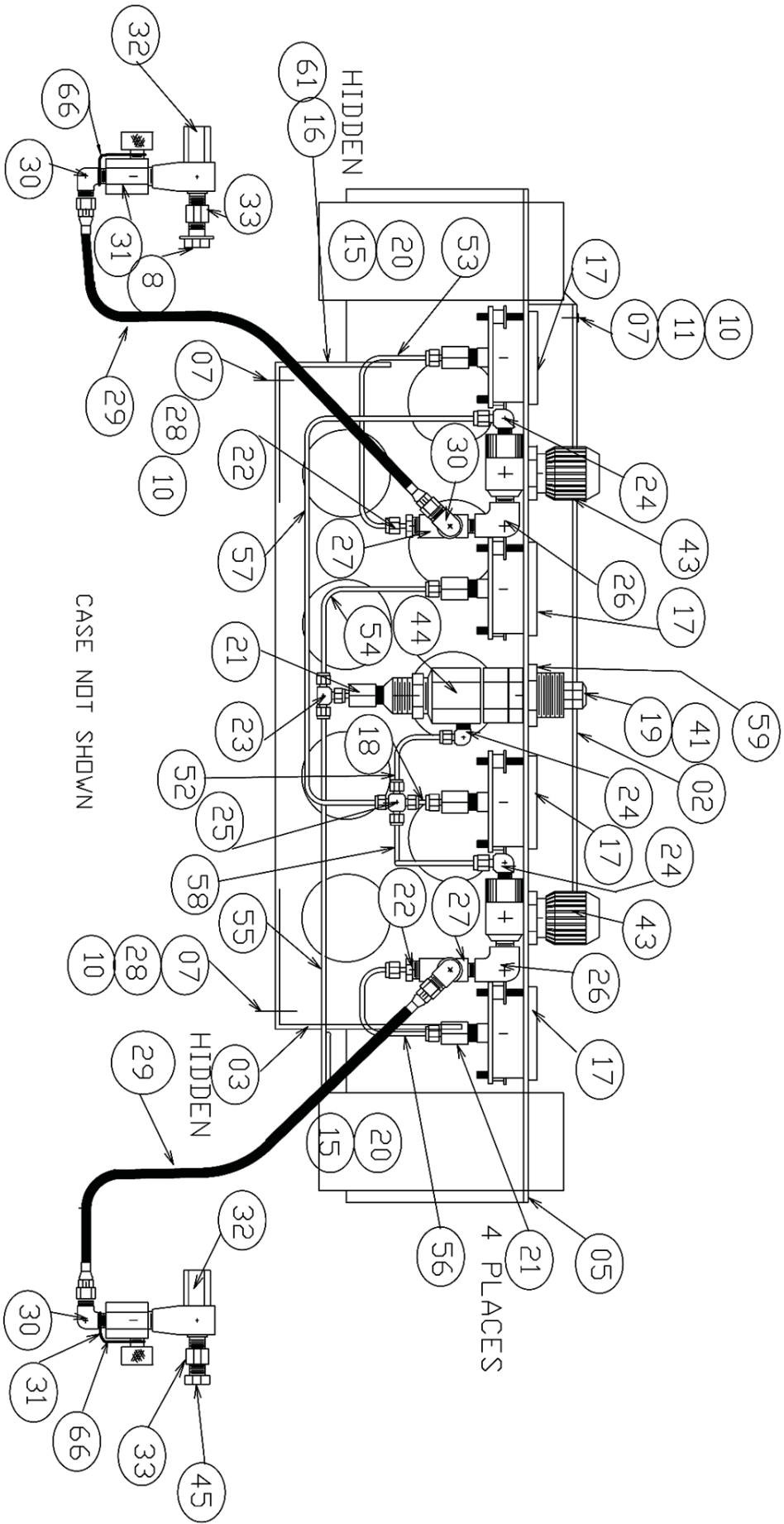

# END VIEW

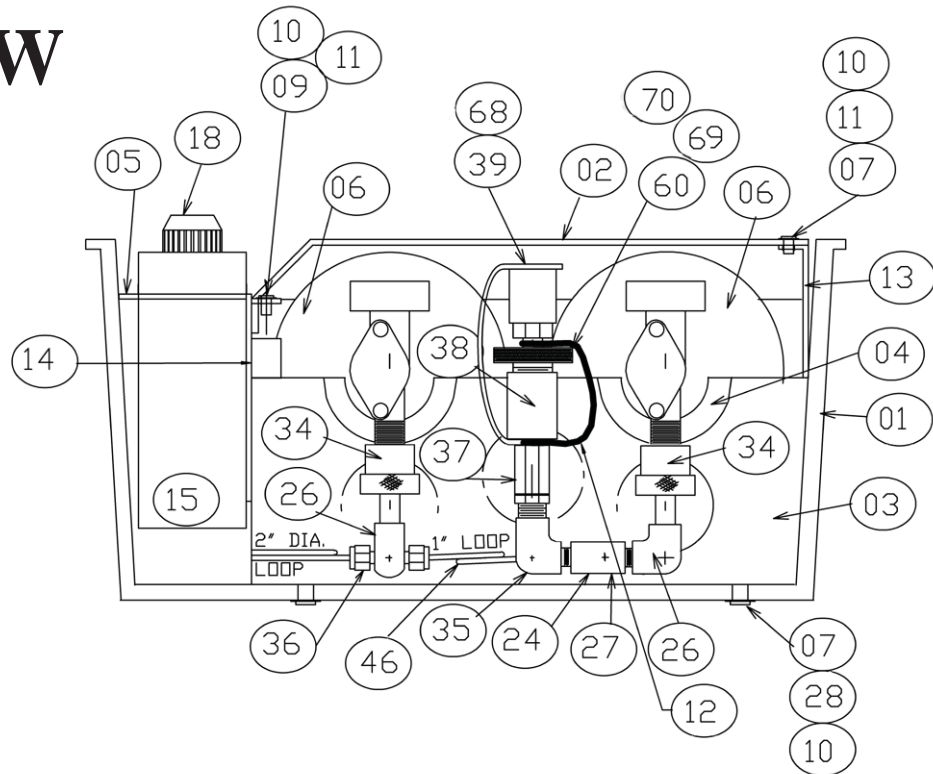

ITEM	REQ 'D	PART NO.	AQUALUNG PART NO.	DESCRIPTION
01	1	1650	103201	CASE, PELICAN WITH WHEELS
02	1	FRM1**	103202	TOP PLATE, 14 $\frac{1}{4}$ " X 16 $\frac{1}{4}$ " .125 ALUM. 5052-H32
03	1	FRM1**	103203	SUPPORT, 6" X 14 1/8" .125 ALUM. 5052-H32
04	1	PRS17	103204	GROMMET, 1.5", ALTER
05	1	FRM1**	103206	BRACKET 11 $\frac{1}{2}$ " X 28 $\frac{1}{2}$ ".125 ALUM. 5052-H32
06	2	CYL1	103207	CYLINDER, CARBON COMPOSITE, 4500PSI, 87 CU. FT. NO VALVE
07	8	BLT3	103208	SCREW, 1/4-20 X 1 SS
08	1	MRS22	103137	BRASS PLUG, 7/16 X 20
09	2	MRS23	103211	BOLT, 1/4-20 X 1 $\frac{1}{2}$ SS
10	10	MRS50	103212	INSERT, 1/4 - 20
11	6	WA1	103213	WASHER, 1/4" FLAT, SS
12	1	MRS21	103214	LANYARD
13	1	FRM1**	103216	BACK PLATE, 11" X 20 7/8" .125 ALUM. 5052-H32
14	2	FRM1**	103217	1/8 WALL X 3/4 X 3/4 X 3/4" SQ ALUM. TUBE
15	2	FRM1**	103218	TUBE, 2 7/8" OD. X 2 1/4" ID. X 6 7/8" LG
16	1	FRM1**	103219	REST, 5 7/8" X 14 1/8" ".125 ALUM. 5052-H32
17	4	GAG1	103221	GAUGE, 6000 PSI, SST W/ PANEL MOUNT CLAMP, DRY GAUGE, 2.5"
18	1	MRS5-ASY	103222	TUBING, GAUGE, 1/8" X .028 WALL 304SS
19	1	MRS13	103223	NUT, ACORN
20	2	FRM1**	103224	BOTTOM, 3/4" X 2 5/16".125 ALUM. 5052-H32

\*\* FRM1 Items available as assembly only.

ITEM	REQ'D	PART NO.	AQUALUNG PART NO.	DESCRIPTION
21	4	MRS3-ASY	103226	CONNECTOR, 1/8" TUBE X 1/4" FNPT, SST
22	2	PRS2	103227	CONNECTOR, 1/4" MNPT X 1/8" TUBE, SST
23	1	MRS2	103228	TEE TUBE UNION, 1/8"
24	4	PRS8	103229	ELBOW, 1/4" MNPT X 1/8" TUBE
25	1	MRS1	103231	CROSS, 1/8" TUBE SS
26	4	FESS	103232	ELBOW, SS, FEMALE, 1/4" FNPT
27	3	STSS	103233	TEE, STREET, SST 1/4"
28	4	WA3	103234	WASHER, FENDER 1/4" SS
29	2	HOSI	103236	HOSE, FILL MRS III
30	2	CTXSS	103237	ELBOW, SS, 1/4" FLARE X 1/4" MNPT
31	2	712	103238	BLEEDER, INLINE MXF ALUMINUM
32	2	PRS21	103239	FILL ADAPTER, #4 SAE X 1/4" FNPT
33	2	NUT2	103241	NUT COUPLING, 7/16"—20 SST
34	2	835	103242	ADAPTER, FILL, 4.5 ALUM.
35	1	SESS	103243	ELBOW, STREET, SS 1/4"
36	1	MRS14	103244	TEE, 1/8" TUBE X 1/4" MNPT, SS MALE BRANCH
37	1	955SSMM	103246	CHECK VALVE, SS, 1/4" MNPT
38	1	DIN-F	103247	ADAPTER, DIN WITH 55° THREAD BY 1/4" FNPT
39	1	347-1	103248	CGA 347 TO 1/4" FNPT BRASS
40	1	MRS24	103250	MRS III OPERATING INSTRUCTIONS
41	1	MRS12	103249	SCREW SET
42	2	PAD1	103251	PAD, RUBBER, 4" X 21"x.25" ADHESIVE BACK
43	2	YVA3010A	103252	PANEL FILL VALVE
44	1	1120/ASSY	103253	PRESET REGULATOR, 5000 PSI
45	1	MRS25	103254	BRASS PLUG 7/16"—20
46	1	MRS11-ASY	103256	TUBING, CYLINDER 1/8" X .028 WALL, 304SS
47	1	MRS17	103257	LABEL, REGULATOR, 3/8" X 3 1/2"
48	1	MRS16	103258	LABEL, SUPPLY PRESSURE, 3/8" X 3 1/2"
49	1	MRS15	103259	LABEL, FILL #1, 3/8" X 3 1/2"
50	1	MRS18	103261	LABEL, REGULATED PRESSURE 3/8" X 3 1/2"
51	1	MRS19	103262	LABEL, FILL #2, 3/8" X 3 1/2"
52	1	MRS7-ASY	103263	TUBING, REGULATED, 1/8" X .028 WALL, 304SS
53	1	MRS4-ASY	103264	TUBING, FILL #1, 1/8" X .028 WALL, 304SS
54	1	MRS20-ASY	103266	TUBING, SUPPLY GAUGE, 1/8" X .028 WALL, 304SS
55	1	MRS10-ASY	103267	TUBING, 1/8" X .028 WALL, 304SS
56	1	MRS6-ASY	103268	TUBING, #2 SUPPLY, 1/8" X .028 WALL, 304SS
57	1	MRS8-ASY	103269	TUBING, #1 JUNCTION, 1/8" X .028 WALL, 304SS
58	1	MRS9-ASY	103271	TUBING, #2 JUNCTION, 1/8" X .028 WALL, 304SS

ITEM		PART NO.	AQUALUNG PART NO.	DESCRIPTION
59	1	NUT1	103272	NUT, MRSIII, 1.25-12, 1.5 HEX
60	1	PRS6	103273	HANDWHEEL ASSEMBLY, DIN X ¼" MNPT
61	1	TRIM	103274	TRIM, FITS 1/8" MATERIAL
62	2	VAL1	103276	VALVE, SUPPLY CYLINDER, CGA 347
63	2	FRM1	103277	GUSSET, 1½" X 1½" .125 ALUM. 5052-H32
64	2	FRM1	103278	PLATE, ¾" X 1¼" .125 ALUM. 5052-H32
65	2	MRS26	103279	LABEL, .5 X 1.75, AVERY 5267
66	2	59	103281	BLEEDER KEEPER
67	1	PAD2	103348	PAD, RUBBER, 4" X 21" X .375" ADHESIVE BACK
68	2	RCAP	100755	RUBBER COVER FOR MRS INLET
69	1	PRS6-1	820040	O-RING
70	1	PRS6-2	820039	O-RING

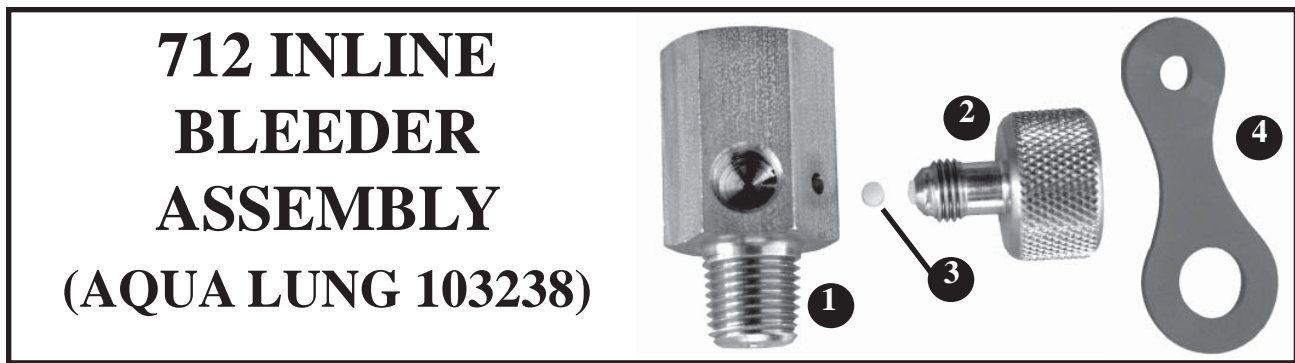

ITEM	REQ'D	PART NO.	AQUALUNG PART NO.	DESCRIPTION
		712	103238	INLINE BLEEDER, COMES WITH 1, 2, AND 3 BELOW
1	1	712BODY	103318	BLEEDER BODY
2	1	712KNOB	103347	KNOB FOR BLEEDER
3	1	712SSTIP	100774	TIP
4	1	59	103281	BLEEDER KEEPER

# FILL VALVE ASSEMBLY (YVA3010A)

ITEM	REQ'D	PART NO.	AQUALUNG PART NO.	DESCRIPTION
1	1	YVABODY	103282	VALVE BODY
2	1	YVAKIT-5 *	103283	COPPER GASKET
3	1	YVAKIT-1 *	103284	VALVE SEAT
4	1	YVASTEM	103286	VALVE STEM
5	1	YVAKIT-3 *	103287	THIN PACKING
6	1	YVAKIT-4 *	103288	THICK PACKING
7	1	YVABONNET	103289	BONNETT NUT
8	1	YVAKNOB-1 **	103291	KNOB
9	1	YVASPRING	103292	SPRING
10	1	YVANUT	103293	VALVE NUT
11	1	YVAKNOB-2 **	103294	KNOB CAP

\* These items are contained in the YVA KIT, and cannot be purchased separately

\*\* YVA KNOB (100778) consists of YVAKNOB-1 and YVAKNOB-2, and are only purchased as a unit.

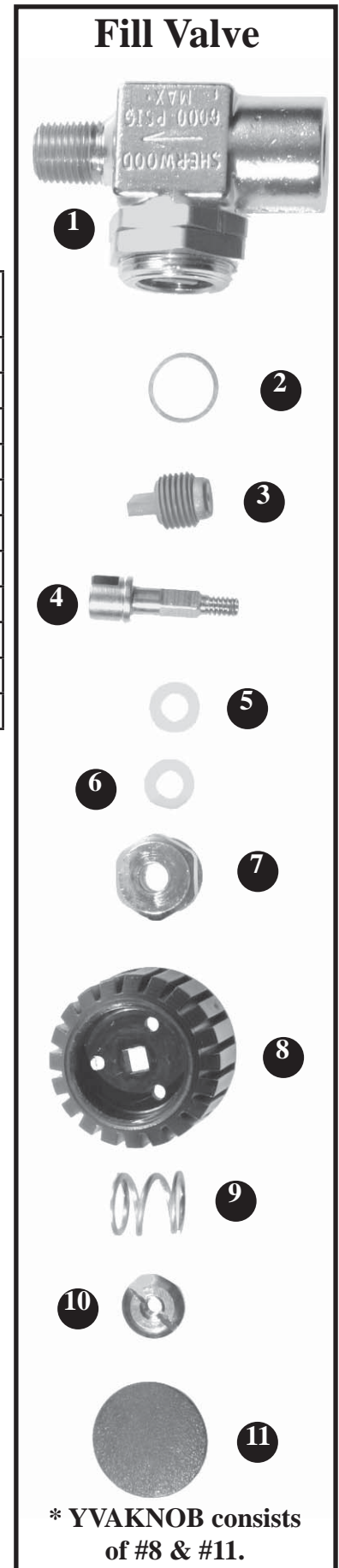

# SUPPLY CYLINDER VALVE (#VAL1 or #103276)

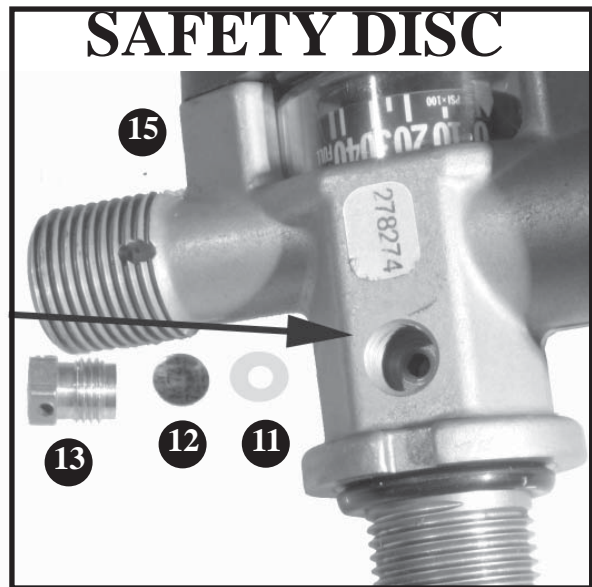
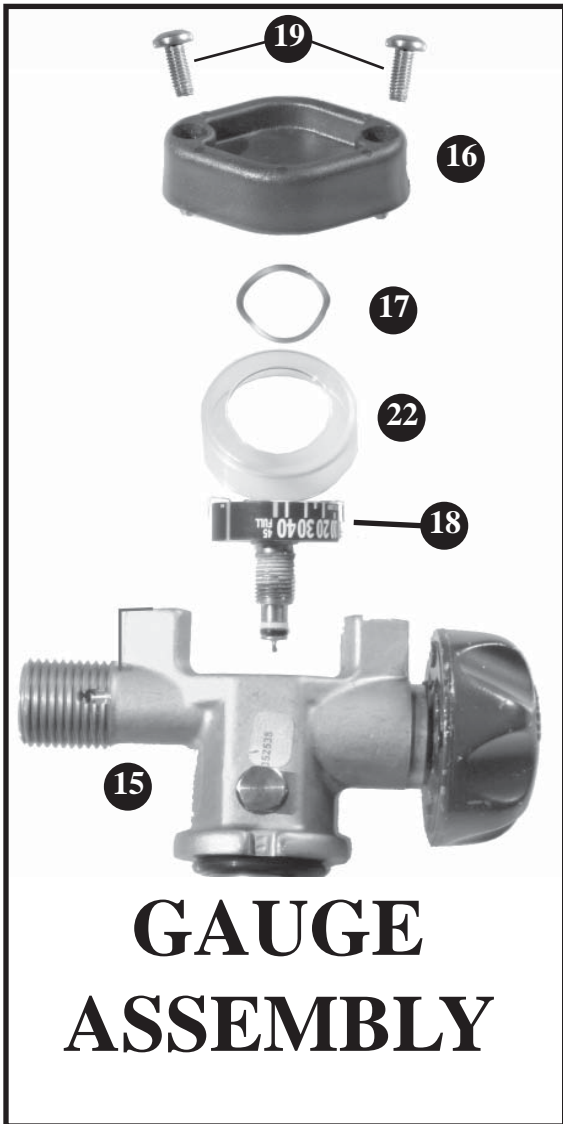
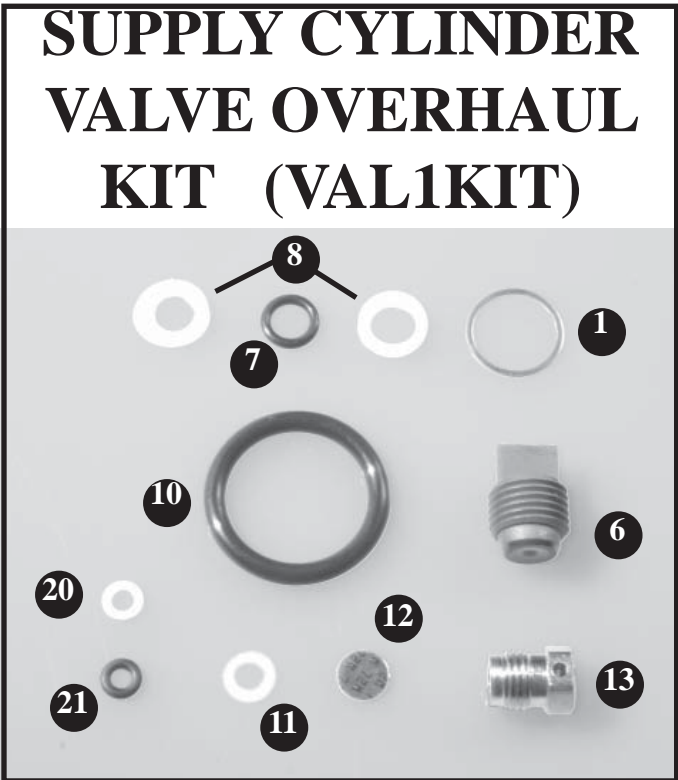
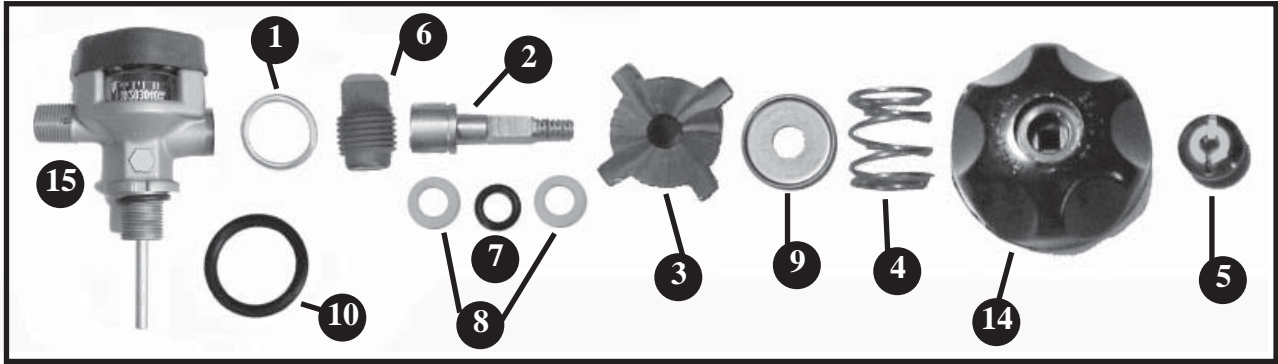

# SUPPLY CYLINDER VALVE PARTS BREAKDOWN

ITEM	REQ'D	PART NO.	AQUALUNG PART NO.	DESCRIPTION
		VAL1	103276	SUPPLY CYLINDER VALVE
1 +	1	VAL1-13	103296	COPPER GASKET
2	1	VAL1-15	103297	VALVE STEM
3	1	VAL1-16	103298	BONNET NUT
4	1	VAL1-17	103299	LOCK SPRING
5	1	VAL1-18	103301	VALVE NUT
6 +	1	VAL1-7	103302	VALVE SEAT
7 +	1	VAL1-5	103303	O-RING
8 +	2	VAL1-6	103304	TEFLON WASHER
9	1	VAL1-14	103306	WEAR WASHER
10 +	1	VAL1-8	103307	O-RING
11 +	1	VAL1-4	103308	SAFETY DISC GASKET
12 +	1	VAL1-3	103309	SAFETY DISC
13 +	1	VAL1-9	103311	SAFETY DISC PLUG
14	1	VAL1-19	103312	KNOB
15	1	VAL1-20	103313	VALVE BODY. NOT AVAILABLE SEPARATELY
16	1	VAL1-21	103314	BUMPER GUARD ASSEMBLY
17	1	VAL1-22	103316	SPRING, WAVE WASHER
18	1	VAL1-23	103317	GAUGE ASSEMBLY
19	2	VAL1-26	103344	SCREW FOR BUMPER
20 +	1	VAL1-1	103319	TEFLON BACKUP RING
21 +	1	VAL1-2	103321	O-RING
22	1	VAL1-25	103322	GAUGE COVER
23		VAL1KIT	103346	SUPPLY VALVE OVERHAUL KIT

+ Part of valve rebuild kit. Parts cannot be bought separately.

# SEA FILL ADAPTER (PRS-21)

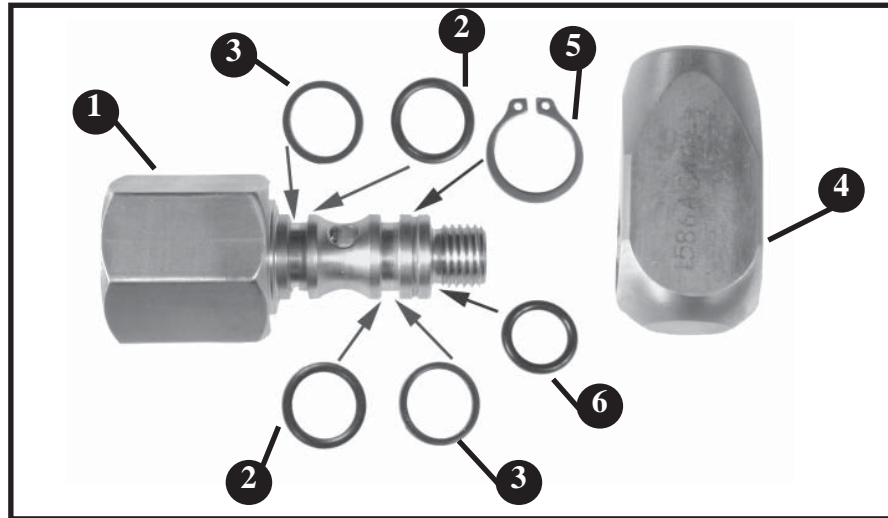

## ADAPTER OVERHAUL KIT (PRS21KIT)

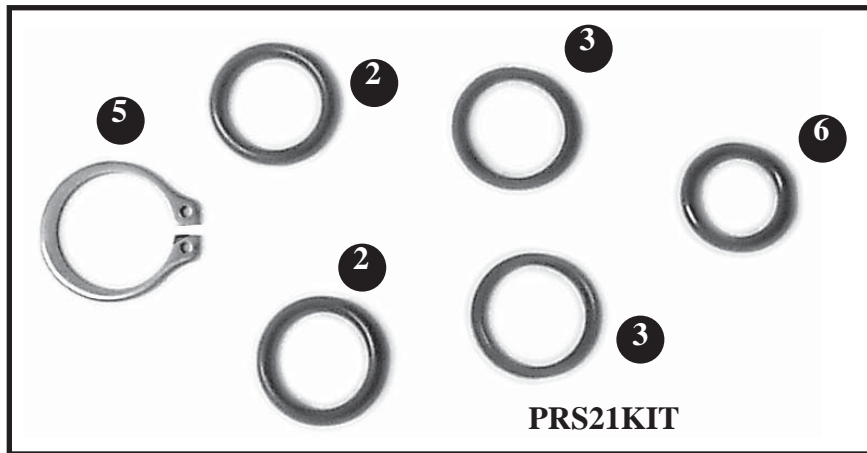

ITEM	REQ'D	PART NO.	AQUALUNG PART NO.	DESCRIPTION
		PRS21KIT	100782	ADAPTER OVERHAUL KIT ITEMS 2,3,5 & 6 BELOW
1**	1	PRS21-1	103333	SPINDLE
2	2	PRS21-3	100771	O-RING
3	2	PRS21-2	100770	BACK-UP RING
4**	1	PRS21-4	103334	BODY
5	1	PRS21-5	100772	SNAP RING
6	1	PRS21-6	100773	O-RING

*\*\*Items 1 & 4 cannot be purchased separately.*

**ONE-YEAR MAINTENANCE KIT MRSKIT1  
(AQUA LUNG 100703)**

ITEM	REQ'D	PART NO	AQUALUNG PART NO.	DESCRIPTION
1	4	PRS21-2	100770	BACKUP RING
2	4	PRS21-3	100771	O-RING
3	2	PRS21-5	100772	SNAP RING
4	2	PRS21-6	100773	O-RING
5	2	712SSTIP	100774	TIP
6	2	010	100775	O-RING - CYL FILL ADAPTER
7	2	VAL1-8	103307	O-RING FITS VAL1 NECK

**FIVE-YEAR MAINTENANCE KIT MRSKIT2  
(AQUA LUNG 100704)**

ITEM	REQ'D	PART NO	AQUALUNG PART NO.	DESCRIPTION
1	4	PRS21-2	100770	BACKUP RING
2	4	PRS21-3	100771	O-RING
3	2	PRS21-5	100772	SNAP RING STAINLESS
4	2	PRS21-6	100773	O-RING
5	2	712SSTIP	100774	TIP
6	2	010	100775	O-RING
7	2	VAL1-8	103307	O-RING FITS VAL1 NECK
8	2	YVAKIT	100777	REPAIR KIT YVA VALVE
9	2	YVAKNOB	100778	KNOB
10	1	1120KIT	100776	KIT FOR 1120 REGULATOR
11	1	955KIT	100781	REBUILD KIT, 955SSMM
12	2	VAL1-1	103319	TEFLON B/U RING FOR VAL1
13	2	VAL1-2	103321	O-RING, FITS VAL1
14	2	VAL1-3	103309	BURST DISC FOR VAL1 SAFETY
15	2	VAL1-4	103308	NYLON WASHER FOR VAL1 SAFETY
16	2	VAL1-5	103303	O-RING, FITS VAL1
17	4	VAL1-6	103304	TEFLON WASHER FOR VAL1 STEM
18	2	VAL1-7	103302	PLUG SEAT ASSEMBLT FOR VAL1
19	2	VAL1-9	103311	SAFETY DISC PLUG
20	2	VAL1-13	103296	COPPER GASKET FITS VAL1
21	1	PRS6-1	820040	O-RING FOR PRS6 FOR SEAL
22	1	PRS6-2	820039	O-RING FOR PRS6 INTERNAL

# CHECK VALVE OVERHAUL (#955SSMM or #100781)

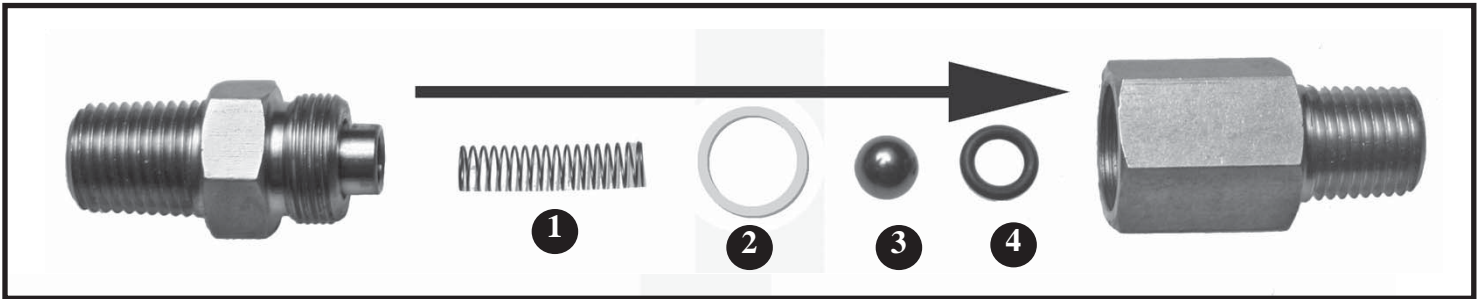

ITEM	REQ'D	PART NO.	DESCRIPTION
1	1	955KIT-1**	SPRING (Cannot be purchased separately.)
2	1	955KIT-2**	GASKET (Cannot be purchased separately.)
3	1	955KIT-3**	BALL (Cannot be purchased separately.)
4	1	955KIT-4**	O-RING (Cannot be purchased separately.)
	1	955KIT	Items 1, 2, 3, and 4 above.

+\*\* Part of valve rebuild kit. Parts cannot be bought separately.

Parts needed: 955KIT and Christo-Lube

1. Using an 11/16" and a 3/4" wrench, separate the halves of the check valve.
2. Remove the spring (1) ball (3) gasket (2) and the o-ring (4). Discard.
3. Using a soft cloth or papertowel clean the internal surfaces of the body. Open 955KIT. Lubricate the o-ring (4) with a small amount of non-toxic lubricant (Christo-lube). NOTE: Do not leave heavy concentrations
4. Place the new o-ring (4) into the body, pushing into the groove.
5. Place a thin film of lube on the ball (3), place the ball into the body on the o-ring.
6. Place the gasket (2) into place in the body.
7. Place the spring (1) in the opposite half of the body
8. Reassemble the 2 halves.

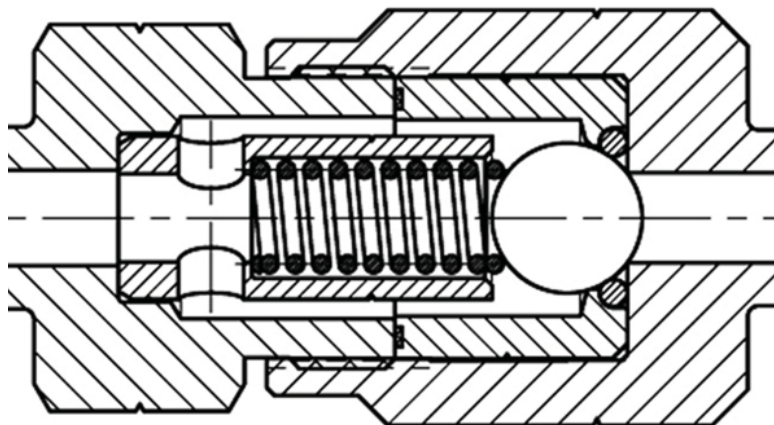

# PRS6 OVERHAUL

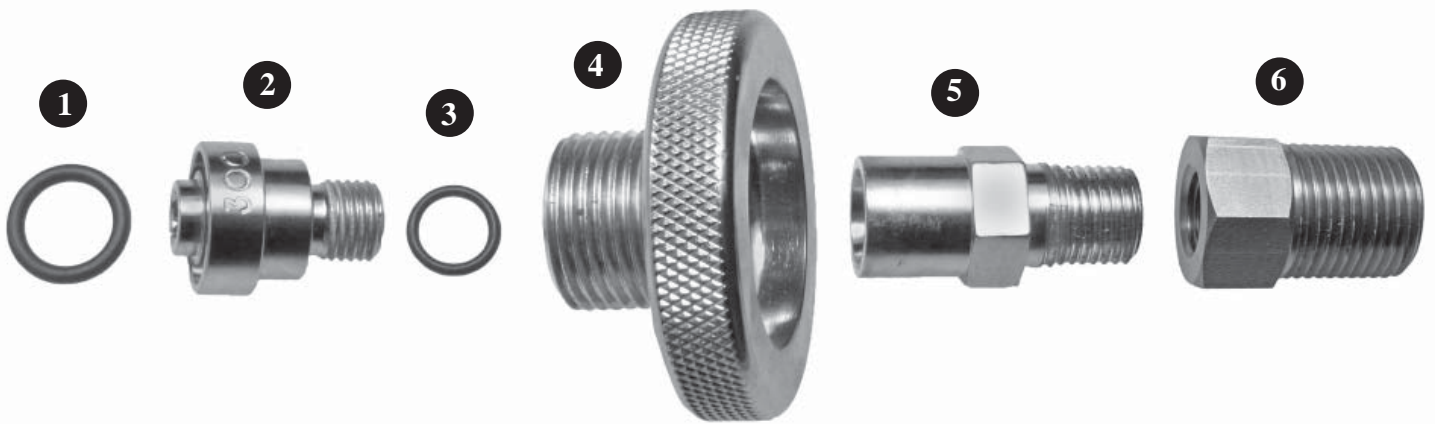

ITEM	REQ'D	PART NO.	AQUALUNG PART NO.	DESCRIPTION
		PRS6		
1	1	PRS6-1	820040	O-RING
2	1	PRS6-3	106058	STEM (Cannot be purchased separately.)
3	1	PRS6-2	820039	O-RING
4	1	PRS6-4	108657	HANDWHEEL (Cannot be purchased separately.)
5	1	PRS6-5	054159	1/4"NPT FITTING (Cannot be purchased separately.)
6	1	347-1	103248	CGA 347 TO 1/4" FNPT BRASS

1. To disassemble, hold 1/4" NPT fitting (5) using 11/16" socket. Using a 6mm Allen wrench, unscrew stem (2) with a counter-clockwise motion.
2. Remove O-rings from stem, using O-ring pick. Discard.
3. The 820039 O-ring (3) on the PRS/MRS DIN connector must have a light coat of non-toxic lubricant (Christo-Lube) applied prior to being installed on the assembly. NOTE: Do not apply any lubricant to the 820040 O-ring (1).
4. Install lubricated O-ring (3) over the threads of the stem (2) taking care to not damage the O-ring.
5. Install O-ring (1) all the way back into the O-ring groove of stem (2).
6. Place the handwheel (4) over the 1/4" NPT fitting (5) with the threads pointed upward.
7. Thread stem (2) into 1/4" NPT fitting (5) using a 6mm Allen wrench. Use 11/16" socket to hold 1/4" NPT fitting.
8. Torque stem (2) to 1/4" NPT fitting (5) -- 40.0 +/- 5.0 inch pounds.

# PRESET REGULATOR (1120)

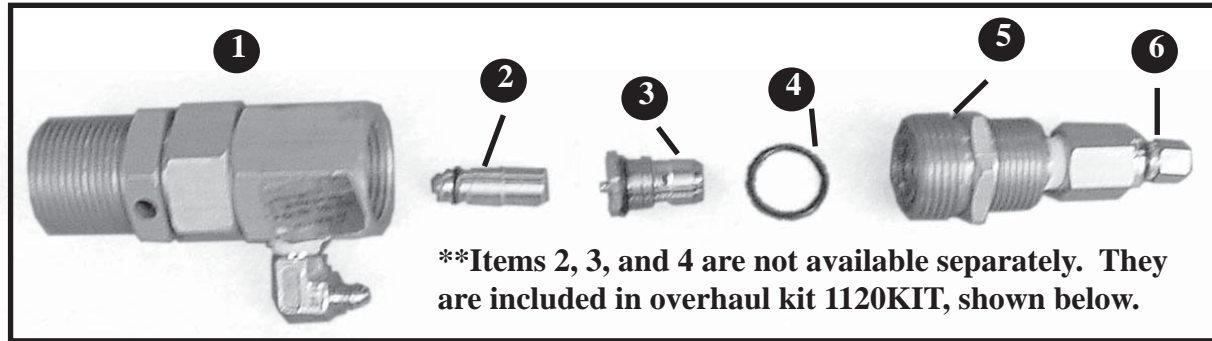

# PRESET REGULATOR OVERHAUL KIT (1120KIT)

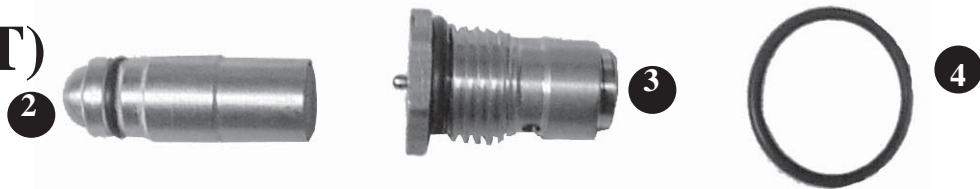

1120KIT1--1\*\*  
PISTON

1120KIT1--2\*\*  
7 O-RING

1120KIT1--3\*\*  
SEAT 8

\*\* 1120KIT-1 comes assembled in 1120KIT. Breakdown at left is shown for information only, in case parts become separated. Parts cannot be bought separately.

**1120KIT-1  
BREAKDOWN**

ITEM	REQ'D	PART NO.	AQUALUNG PART NO.	DESCRIPTION
		1120KIT	100776	KIT FOR 1120 REGULATOR, all items below
1	1	1120-1	103336	SPRING CAP
2	1	1120KIT-1	103337	PISTON
3	1	1120KIT-2	103338	CARTRIDGE
4	1	1120KIT-3	103339	O-RING
5	1	1120-2	103341	BODY
6	1	PRS10	103342	FITTING
7	1	1120KIT-1-2		O-RING **
8	1	1120KIT-1-3		SEAT **

\*\*1120KIT-1-2 and 1120KIT-1-3 are part of 1120KIT-1. Cannot be purchased separately.

# MRS III FLOW DIAGRAM

Revision	Date	Description
(A)	5/18/06	Added V6 and V7

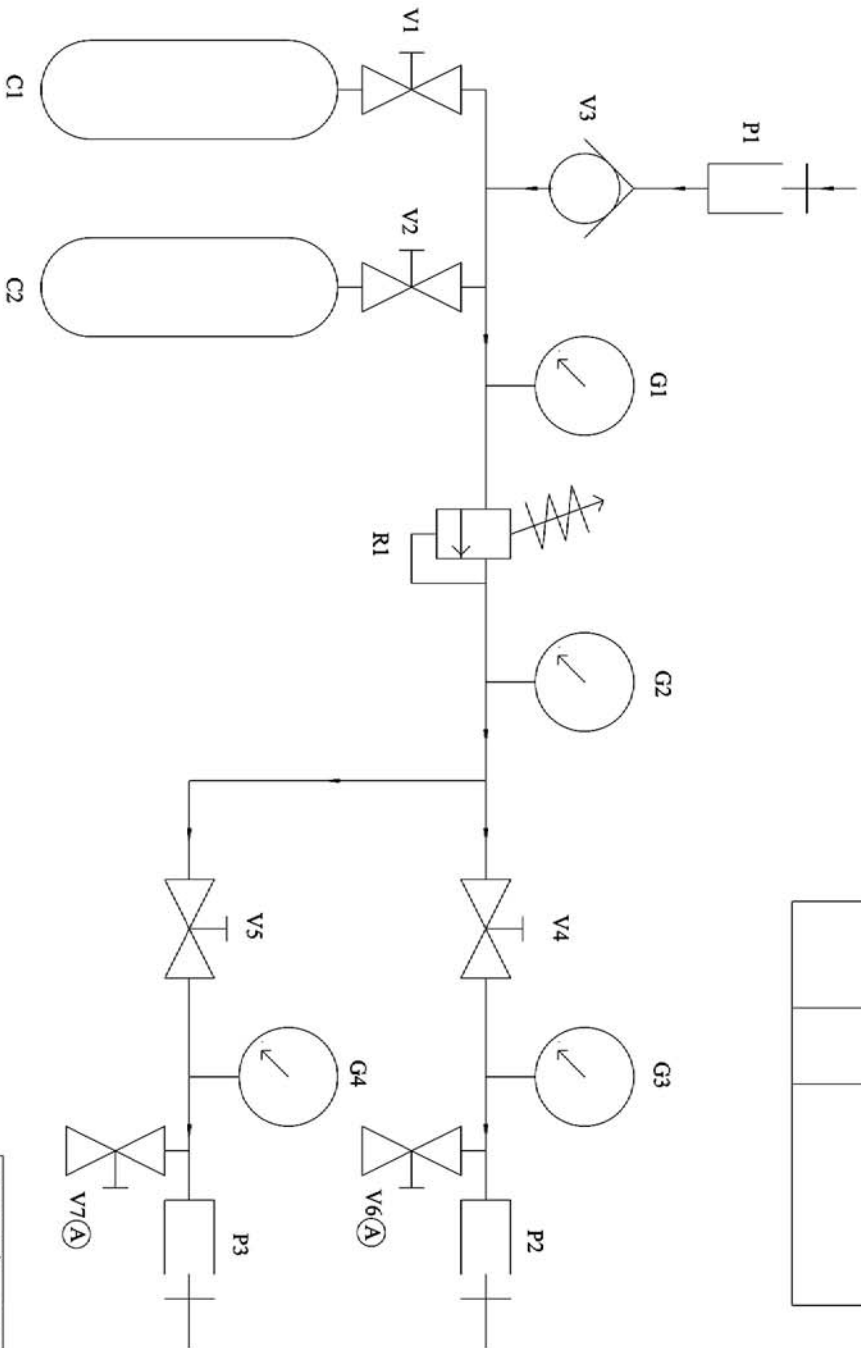

- C1 Storage Cylinder
- C2 Storage Cylinder
- G1 Supply Pressure Gauge
- G2 Regulated Pressure Gauge
- G3 Fill #1 Gauge
- G4 Fill #2 Gauge
- P1 Refill Port
- P2 Fill Port #1
- P3 Fill Port #2
- R1 Regulator
- V1 Supply Cylinder Valve
- V2 Supply Cylinder Valve
- V3 Check Valve
- V4 Fill Valve #1
- V5 Fill Valve #2
- (A) V6 Bleeder Valve, Fill 1
- (A) V7 Bleeder Valve, Fill 2

<b>BREATHING AIR SYSTEMS</b> 8833 East Broad Street Reynoldsburg, OH 43068 1-800-971-2479		Title: MRSIII	
		S/N#	Drawn by: Frank
FLOW Diagram		Date: 3/21/2006	
Sht. 1 of 1			

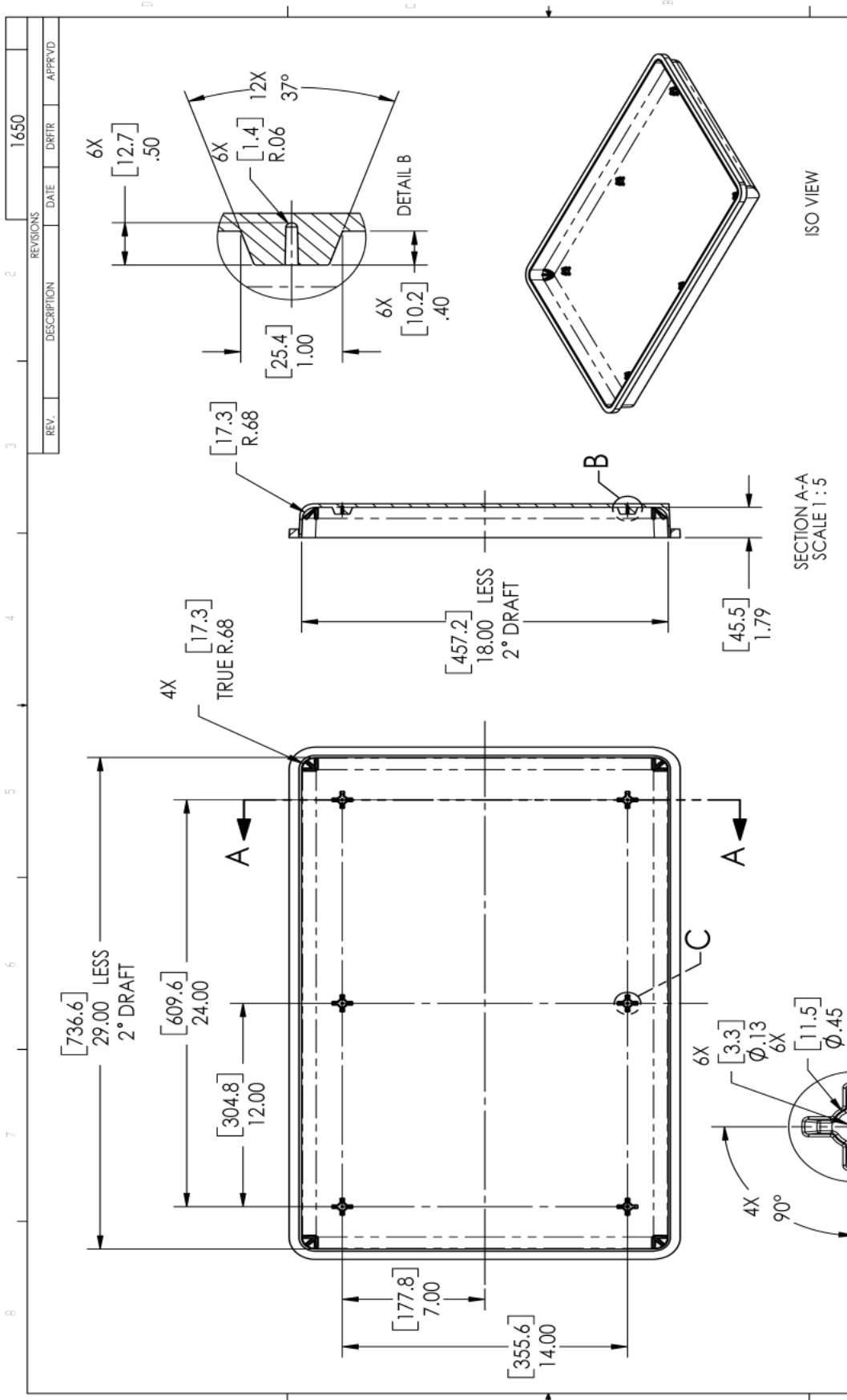

REV.		DESCRIPTION		REVISIONS		DATE		DRFR		APPRVD	
1650											
UNSPECIFIED TOLERANCES			APPROVALS			DATE			TITLE		
 <b>PELICAN™</b> <i>You break it, we replace it... forever.</i>			PERSON			DATE			1650 CUBE CASE, TOP		
			CHECKED			DATE			INTERNAL GEOMETRY		
			APPROVED			DATE			DRAWING NO.		
This Drawing contains information proprietary to Pelican Products Inc. any reproduction disclosure or use of this drawing requires written permission of Pelican Products Inc.			SIZE			SCALE			DRAWING NO.		
			B			1:1			1650		
DO NOT SCALE DRAWING											
SHEET 1 OF 1											

1. ALL DIMENSIONS ARE TO INTERNAL GEOMETRY OF CASE.  
 NOTES: UNLESS OTHERWISE SPECIFIED.

