

wtx series  
owner's manual





## Copyright Notice

This manual is copyrighted, all rights reserved. It may not, in whole or in part, be copied, photocopied, reproduced, translated or reduced to any electronic medium or machine-readable form without prior consent in writing from Aqua Lung International. It may not be distributed through the internet or computer bulletin board systems without prior consent in writing from Aqua Lung International.

©2006 Aqua Lung International  
WTX Series Owner's Manual  
pn 18346 rev. 9/06

## Warnings, Cautions, & Notes

Pay special attention to information provided in warnings, cautions and notes that are accompanied by one of these symbols:



**WARNINGS** indicate a procedure or situation that may result in serious injury or death if instructions are not followed correctly.



**CAUTIONS** indicate any situation or technique that will result in potential damage to the product, or render the product unsafe if instructions are not followed correctly.



**NOTES** are used to emphasize important points, tips and reminders.



**WARNING:** This manual provides essential instruction for the proper fitting, adjustment, inspection and care of your new BC. Because Apeks BC's utilize patented technology, it is very important to take the time to read these instruction in order to understand and fully enjoy the features that are unique to your specific model. Improper use of this BC could result in serious injury or death.

## CONTENTS

### INTRODUCTION 3

### SAFETY INFORMATION 4

General Precautions & Warnings 4

### FEATURES 6

WTX Harness 6

Apeks Buoyancy Cells 9

Single Cylinder Buoyancy Cells 9

Twin Cylinder Buoyancy Cells 10

Twin Cylinder Redundant Buoyancy Cells 12

### ASSEMBLING YOUR WTX SYSTEM 14

Mounting a Single Cylinder Buoyancy Cell  
Using Dual Tank Bands 14

Threading the Cam Buckle 16

Securing Your Buoyancy System  
to the Cylinder Using Tank Bands 17

Inserting an Apeks Back Plate 18

Mounting a Single Cylinder or Twin Cylinders  
using Nuts and Bolts 19

Adjusting the Crotch Strap 19

Customizing the Shoulder Hardware 20

Positioning the Waist Buckle 21

Attaching the MP Hose to the First Stage 22

### USING YOUR WTX SYSTEM 23

Pre-dive Inspection 23

Donning and Adjustment Procedures 24

Inflation Methods 25

Oral Inflation 25

Power Inflation 25

Deflation Methods 26

Deflation via Oral Inflator 26

Overpressure Relief (OPR)/Dump Valve 26

Post-dive Care and Maintenance 28

### DEALER INSPECTION & SERVICE 29

### SERVICE RECORD 30

### WARRANTY INFORMATION 31

## INTRODUCTION

Congratulations—*and thank you*—for choosing Apeks. Whether your diving takes you to the ghost ships of Scapa Flow or the cenotes of the Mexican Yucatan, your new Apeks technical harness and buoyancy cell system has been designed and manufactured with pride, according to the most exacting standards for quality and performance.

Provided that you are the original owner and that the product has been purchased from an Authorized Apeks Dealership, your WTX product is covered by a Limited Lifetime Warranty. Be sure to read the warranty section of this manual completely and remember to save your sales receipts. Copies of these receipts must be presented whenever obtaining warranty service.

The function and performance of your WTX harness and buoyancy cell relies greatly on the care and maintenance it will receive, in addition to regularly scheduled dealer service. Before you dive with your Apeks WTX product, it is therefore important to read this manual in its entirety; to become familiar with its features, as well as correct procedures for setup, pre-dive inspection, and post-dive maintenance.

Please read on to learn how you can obtain the maximum enjoyment from your Apeks WTX product, and maintain its like-new performance for many years to come.

## SAFETY INFORMATION

### General Precautions & Warnings



Before using this buoyancy compensator (BC), you must receive instruction and certification in SCUBA diving and buoyancy control from a recognized training agency. Use of SCUBA equipment by uncertified or untrained persons is dangerous and can result in injury or death.



Read this owner's manual completely before attempting to use your BC, and become familiar with it first in a controlled environment such as a swimming pool, in order to weight yourself properly and to become comfortable with using its many features and adjustments.



Before every dive, perform a complete pre-dive inspection according to the procedure prescribed in this manual, to ensure that all components are functioning properly and no signs of damage or leaks are present. If you find that your BC is not functioning properly or is damaged, remove it from service until it can be repaired by an authorized Apeks Dealer.



Your BC is not a lift bag. **DO NOT** use it to bring heavy objects to the surface. Doing so may cause permanent damage to the BC, and could also result in serious injury or death due to embolism or decompression sickness.



In an emergency such as an out of air situation or uncontrolled descent, it is important to remove and jettison weight immediately. **DO NOT** depend solely on using your BC's power inflator to lift you to the surface.



In the event of an uncontrolled, rapid ascent, it is important to immediately begin venting air from the BC. Continue venting air to slow your ascent rate if neutral buoyancy cannot be reestablished.



**DO NOT** inhale from your oral inflator. The BC may contain harmful contaminants or gasses, which could cause suffocation or injury.



Factory prescribed service for this BC must be performed at least once annually by a factory trained technician who is employed by an authorized Apeks Dealer. Annual service consists of a complete overhaul of the power inflator, and a general air leak inspection of the bladder and valve connections.



Disassembly, repair, or lubrication must not be attempted by persons who are not factory trained and authorized by Apeks. Unauthorized service will render the warranty null and void.



This BC is designed for use with compressed air or Nitrox/EAN (enriched air nitrox) mixtures not exceeding 40% oxygen. Any use of gas mixtures with increased oxygen content or the addition of helium or other substances may cause corrosion, deterioration and/or premature aging of the BC leading to component failure of the metal and rubber parts. The component failures could lead to a loss of buoyancy control and/or pressure integrity of the BC resulting in injury or death. Non-standard breathing mixtures may also present a risk of fire or explosion. The use of Nitrox/EAN requires additional training. Failure to observe this warning may result in injury or death. Use only nitrogen/oxygen mixtures containing no more than 40% oxygen.



**WARNING: A buoyancy compensator (BC) is NOT a life jacket! It is not designed to provide face-up flotation in all situations; therefore it does not meet U.S. Coast Guard regulations for a life preserver or personal flotation device (PFD). If you become unconscious in the water without a buddy present to immediately give assistance, you may suffer serious injury or death from drowning.**

Your buoyancy compensator is primarily designed to help you maintain neutral buoyancy while in a comfortably balanced, face-down swimming position underwater. It is also designed to provide you with flotation so that you can rest on the surface, but it is not designed to function as a life preserver or personal flotation device (PFD). In order to meet U.S. Coast Guard regulations, a PFD must be designed so that it automatically rights you to a face-up position and holds your head out of the water on the surface. The design characteristics of a personal flotation device are different from those of a buoyancy compensator. The ability of any flotation device to float you in a face-up position can also be affected by other diving equipment you wear, including a cylinder, weight or exposure suit, and whether it can be inflated before you lose consciousness.

For this reason, it is important to always dive with a buddy, and maintain close proximity with them at all times. Do not depend on any flotation device to hold your face above the surface in the event that you are rendered unconscious in the water while diving.



**WARNING: Although this manual provides some basic guidelines for certain buoyancy control techniques, it is not a substitute for training from a professional diving instructor. Failure to weight yourself properly may create a hazardous condition that could lead to serious injury or death. If you are unsure how to weight yourself in order to achieve optimum buoyancy underwater and on the surface, do not dive until you have obtained the necessary instruction from your diving instructor or an authorized Aqua Lung/Apeks Dealer.**

**If you have any questions regarding your Buoyancy Compensator or these instructions, contact your local dealer or Aqua Lung/Apeks at:  
(760) 597-5000**

## FEATURES

### VERSATILITY THROUGH MODULARITY

Apeks' harnesses, buoyancy cells and accessories are fully modular. They can be mixed and matched to create the ideal system for you and the type of diving you choose to do. In addition, it is easy to customize your system by adding or changing out various pieces of hardware. Whether you want a travel friendly rig to dive in the tropics or a solid technical rig to dive deep, Apeks has the right buoyancy configuration for you.

### WTX Harness

#### ***Removable Back Pad***

The back pad in the WTX harness is considered optional and can be removed. It is held in place by simple hook and loop.



#### ***Back Plate Allowance***

If desired, the WTX harness gives the option of inserting an Apeks back plate for additional weight or support. If you are using nuts and bolts to attach a cylinder or cylinders to the WTX harness, then a back plate must be used.

#### ***Dual Tank Band Capability***

A quick and easy way to attach a single cylinder to the WTX harness is the use of dual nylon tank bands. The bands can be run directly through the back of the harness with or without a back plate installed.

#### ***Open Shoulder Design***

The 2-inch webbing on the shoulders of the WTX harness is an open design. While the WTX harness comes with a 2-inch angled D-ring on each shoulder, the shoulder can be opened up to change out or add additional hardware.

**Crotch Strap**

The crotch strap prevents the unit from riding up on the diver's torso while in the water. It also has a front mounted underwater propulsion vehicle "scooter" ring and a 2-inch accessory D-ring in back.

**Chest Strap**

The chest strap fits across your sternum and keeps the two shoulders from slipping to the sides, ensuring a comfortable and secure fit. The chest strap has the option of being removed for those divers who find it unnecessary.

**Waistband Grommets**

Located alongside each of the waistbands is a set of accessory mounting grommets. The most common use for these is to mount the optional SureLock™ weight pouches. Apeks SureLock™ weight pouches may be ordered separately from your Authorized Apeks Dealer (p/n 388020). Instructions for mounting the weight pockets are included in the weight pocket kit.



**Attachment Points**

Your WTX harness has many attachment points for your various accessories. These recognized attachment points are shown below along with some of their more common uses.

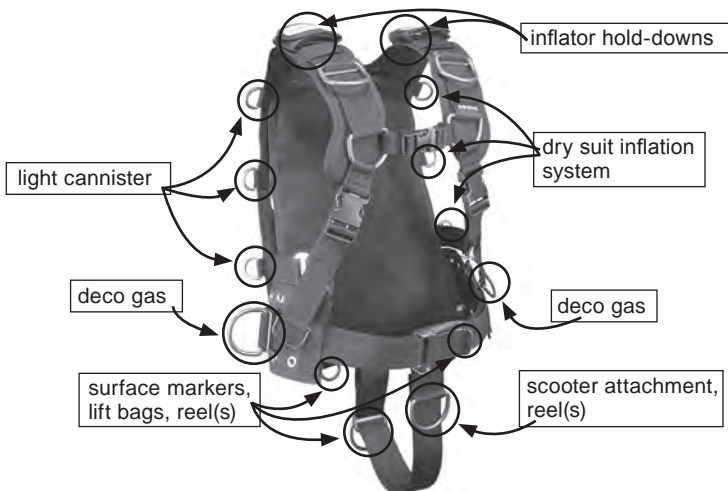

### ***Retaining Loops***

Below each of the shoulder release buckles, there is an elastic retainer loop. These loops can be used to retain excess shoulder strapage or they can be used to retain an accessory such as a small flashlight. There is also a retainer loop located on the crotch strap to retain excess strapage.

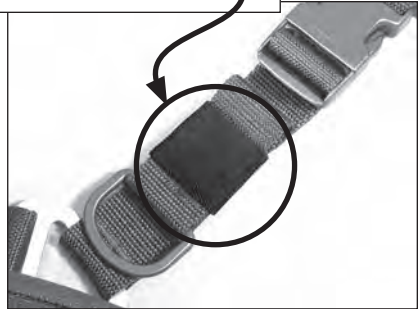

### ***Epaulets (Hold-downs)***

On top of each shoulder are epaulets that hold down the airway(s). Not only do these epaulets hold down the airway(s), they are also SOLAS reflector devices for high visibility. The epaulets are removable and can be repositioned to a new location based upon your needs.

### ***Heavy Duty Metal Waist Buckle***

The waistband on the WTX Harness is secured in front with a heavy-duty metal waist buckle. The metal buckle can be positioned on either side of the waistband allowing for either a left hand or a right hand release.

## APEKS BUOYANCY CELLS

To compliment your choice of harnesses, Apeks manufactures a selection of single cylinder and twin cylinder buoyancy cells in assorted sizes and configurations.

### Single Cylinder Buoyancy Cells

#### *Oval Grommets for Dual Tank Bands*

Each single cylinder buoyancy cell incorporates four oval grommets. These allow the buoyancy cell to be mated directly to the WTX harness or back plate with the use of two standard tank bands. See page 13 for details.



#### *Multiple Metal Grommets for Nut and Bolt Attachment*



Single cylinder buoyancy cells also have multiple sets of central metal grommets that give you the option of mounting with nuts and bolts. These may be used if your single cylinder is equipped with a single cylinder adapter that has two bolts 11 inches (28 cm) on center.

#### *Side Expansion Gussets for Additional Lift Capacity*

Some models have side expansion gussets that allow the cell to expand and provide additional lift capacity without increasing the overall size.

#### *Web Restrictor to Keep Cylinder Close to Body*

Single cylinder buoyancy cells that have a flow through design at the bottom, also have a unique web restrictor at the bottom of the cell that creates an impression for the cylinder to nest into. This prevents a fully inflated cell from pushing the cylinder away from your lower back. Mounted on this web restrictor is a 2" accessory D-ring. This easily accessible D-ring is a great location to attach a surface marker buoy, lift bag, or back-up scooter.

### ***Lower Left Pull Dump***

Each single cylinder buoyancy cell comes standard with a lower left pull dump. This easy-to-reach dump is convenient when dumping while inverted.

### ***Elliptical Corrugated Hose***

The Apeks technical airway found on each cell includes a corrugated hose that has an elliptical cross section. This allows for a lower profile, which reduces drag and lays cleanly over the shoulder.

### ***Safety Cable in the Airway***

A safety cable can be found in the corrugated hose of each Apeks technical airway. This safety cable protects the corrugated hose from hyperextension and tearing that can be caused by any undue stresses such as snags.

### ***Heavy Duty Inflator with Brass Buttons***

Technical diving equipment must be robust and reliable. Apeks' new technical inflator exceeds the challenge. The secret to its reliability is its simplicity. Fewer parts mean less to go wrong and ease of service. Once you hold the precision marine brass buttons in your hand, you will quickly realize that this is not a recreational inflator, but rather a serious tool to meet the dive at hand.

## **Twin Cylinder Buoyancy Cells**

### ***Multiple Grommets for Nut and Bolt Attachment***

Twin cylinder buoyancy cells have three grommets near the top of the center panel and a corresponding oval grommet near the bottom of the center panel. The three grommets allow the diver a choice of three height adjustment settings to achieve proper trim of the cell. Rather than have the lower bolt line up perfectly with a lower hole as other brands require, the oval grommet accommodates bolts that are slightly out of position.



### ***Narrow at Top for Full Access to Valves and Regulators***

Apeks buoyancy cells are designed to be slim at the top to allow the diver's head to tilt back, encourage proper hose placement and to assure that the diver has easy access to the manifold valves.

### ***Lower Left Pull Dump***

Each twin cylinder buoyancy cell comes standard with a lower left pull dump. This easy-to-reach dump is convenient when dumping while in a horizontal or inverted position.

### ***Optional Lower Right Pull Dump***

On the lower right is an additional threaded manifold. While it comes capped off from the factory, it gives the diver the option of adding a second pull dump. A dump valve kit is p/n 42754.

### ***Outer Bag made of 1000D ArmorShield™ Cordura***

The outer bag of the twin cylinder buoyancy cell is made from 1000 denier ArmorShield™ Cordura. This fade-resistant material was chosen for its extreme durability.

### ***Rugged Inner-Bag made of Mil-Spec Material***

The inner bladder of the buoyancy cell is made from a strong, coated fabric. This material meets all necessary military specifications and can be found on lifesaving flotation equipment worn by military pilots.

### ***Inner-Bag Protected from Zipper with V-Diamond™ Rubber***

The inner bladder of the buoyancy cell is protected from getting caught in the outer zipper by using a barrier of V-Diamond™ rubber.

### ***Elliptical Corrugated Hose***

The Apeks technical airway found on each cell includes a corrugated hose that has an elliptical cross section. This allows for a lower profile, which reduces drag and lays cleanly over the shoulder.

### ***Safety Cable in the Airway***

A safety cable can be found in the corrugated hose of each Apeks technical airway. This safety cable protects the corrugated hose from hyperextension and tearing that can be caused by any undue stresses such as snags.

### **Heavy Duty Inflator with Brass Buttons**

Technical diving equipment must be robust and reliable. Apeks' new technical inflator exceeds the challenge. The secret to its reliability is its simplicity. Fewer parts mean less to go wrong and ease of service. Once you hold the precision marine brass buttons in your hand, you will quickly realize that this is not a recreational inflator, but rather a serious tool to meet the dive at hand.

### **Twin Cylinder Redundant Buoyancy Cells**

#### **Multiple Grommets for Nut and Bolt Attachment**

Twin cylinder buoyancy cells have three grommets near the top of the center panel and a corresponding oval grommet near the bottom of the center panel. The three grommets allow the diver a choice of three height adjustment settings to achieve proper trim of the cell. Rather than have the lower bolt line up perfectly with a lower hole as other brands require, the oval grommet accommodates bolts that are slightly out of position.



**Note:** In the following descriptions, the term “front” refers to the bladder closest to the diver when wearing. The term “rear” refers to the bladder furthest away from the diver when wearing.

#### **Narrow at Top for Full Access to Valves and Regulators**

Apeks buoyancy cells are designed to be slim at the top to allow the diver's head to tilt back, encourage proper hose placement and to assure that the diver has easy access to the manifold valves.

#### **Lower Pull Dump**

Each bladder comes standard with a single lower pull dump. The left front pull dump is for the front bladder and the right rear pull dump is for the rear bladder. The easy-to-reach dump valves are convenient when dumping while in a horizontal or inverted position.

### ***Optional Lower Pull Dump***

Each bladder cell has an additional threaded manifold. While it comes capped off from the factory, it gives the diver the option of adding a second pull dump. A dump valve kit is p/n 42754. The additional manifold for the front bladder is on the right front side and the additional manifold for the rear bladder is on the left rear side.

### ***Outer Bag made of 1000D ArmorShield™ Cordura***

The outer bag of the twin cylinder buoyancy cell is made from 1000 denier ArmorShield™ Cordura. This fade-resistant material was chosen for its extreme durability.

### ***Rugged Inner-Bag made of Mil-Spec Material***

The inner bladder of the buoyancy cell is made from a strong, coated fabric. This material meets all necessary military specifications and can be found on lifesaving flotation equipment worn by military pilots.

### ***Inner-Bag Protected from Zipper with V-Diamond™ Rubber***

The inner bladder of the buoyancy cell is protected from getting caught in the outer zipper by using a barrier of V-Diamond™ rubber.

### ***Dedicated Inflator for each Bladder***

The left side inflator is for the front bladder and the right side inflator is for the rear bladder.

### ***Elliptical Corrugated Hose***

The Apeks technical airway found on each cell includes a corrugated hose that has an elliptical cross section. This allows for a lower profile, which reduces drag and lays cleanly over the shoulder.

### ***Safety Cable in the Airway***

A safety cable can be found in the corrugated hose of each Apeks technical airway. This safety cable protects the corrugated hose from hyperextension and tearing that can be caused by any undue stresses such as snags.

### ***Heavy Duty Inflator with Brass Buttons***

Technical diving equipment must be robust and reliable. Apeks' new technical inflator exceeds the challenge. The secret to its reliability is its simplicity. Fewer parts mean less to go wrong and ease of service. Once you hold the precision marine brass buttons in your hand, you will quickly realize that this is not a recreational inflator, but rather a serious tool to meet the dive at hand.

## ASSEMBLING YOUR WTX SYSTEM



**Note:** The terms “hook,” “loop,” and “hook & loop” are used throughout this manual. Hook & Loop is commonly known as Velcro®, which is a trademarked brand of hook & loop. Many of the BC's components have hook & loop attachments, including the waistband, cylinder bands, and weight pouch flaps.

### Mounting a Single Cylinder Buoyancy Cell Using Dual Tank Bands

A single cylinder buoyancy cell may be attached directly to an Apeks back plate or the WTX harness using dual tank bands.

#### **Mounting Directly to the Back Plate**

1. Identify the series of four slots at the top and bottom of the Apeks back plate that accommodate the tank bands.

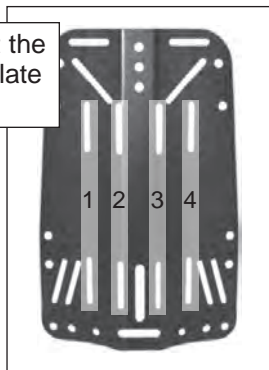

2. While viewing from the back, insert the upper tank band through the upper left slot in the buoyancy cell and on through slot 1 in the back plate. Make sure that the hook and loop of the tank band are facing outward.





3. Weave the tank band through the four upper slots in the back plate.

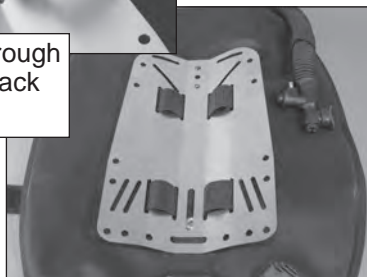

4. After exiting slot 4, the last slot in the series, direct the tank band out the remaining slot of the buoyancy cell.



5. Slide a gripper pad on to the tank band with the ribbed side facing toward the cylinder.

6. Repeat the process for the lower tank band.

### ***Mounting Directly to the WTX Harness***

1. Insert the tank bands through the left slots in the buoyancy cell and on through corresponding web loops in the WTX harness. Make sure that the hook and loop of the tank band are facing outward.

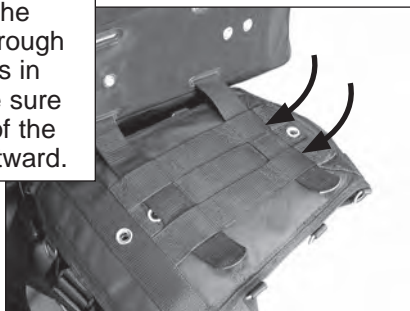

2. After exiting the second webbed loop, direct the tank band out the remaining slot of the buoyancy cell.
3. Slide a gripper pad on to each tank band with the ribbed side facing toward the cylinder (see step 5, p. 15).

## Threading the Cam Buckle



**Note:** The cylinder bands are properly threaded to the buckles when the BC leaves the factory. If rethreading is necessary, follow the procedures in this section.

**Step 1.** Firmly grasp the metal D-ring with your left hand.

**Step 2.** While firmly holding the metal D-ring, rotate the buckle back towards the webbing. The buckle should form an angle with the metal D-ring as shown in the top view.



**Step 3.** Insert band through the metal D-ring, then through the middle slot.

**Step 4.** Insert band through the inside slot.

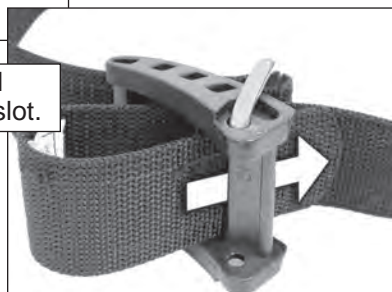

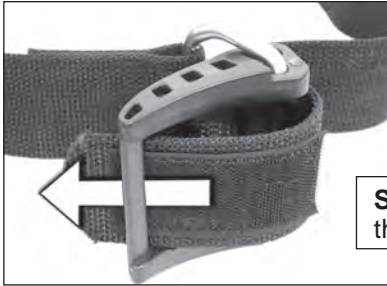

**Step 5.** Insert band through the outer slot.



**Note:** This final threading step is done when the BC is secured to the cylinder (refer to step 4, p. 18). Close the buckle halfway to prevent the webbing from slipping and thread the free end of the band through the open slot in the end of the buckle.

## Securing Your Buoyancy System to the Cylinder Using Tank Bands



**Note:** BC cylinder bands adjust for all standard cylinder diameters: 6.9" (17.5 cm), 7.25" (18.5 cm), and 8.0" (20.3 cm).



1. Remove the free end of the cylinder band from outer slot on the buckle.

2. Slide the cylinder band over the cylinder so that the BC is at the desired position in relation to the cylinder valve. Make sure the cylinder valve air outlet is facing the back of the BC.



3. While holding the cylinder secure, pull the free end of the cylinder band until there is a very tight fit between the pack and the cylinder.

4. Close the buckle halfway to hold the cylinder band taut, and thread the free end of the band through the open slot in the end of the buckle.



5. Pull the cam buckle closed so that it lies flat against the cylinder. Secure the end of the cylinder band with the hook & loop attachment.

6. Test the tightness by pushing/pulling the back frame and cradle.

## Inserting an Apeks Back Plate

To insert an Apeks back plate, remove the back pad and fold down the hook and loop tab at the inside bottom of the harness. Lift open the built in pouch and slide the back plate in as far as it will allow. Close the pouch and secure by repositioning the hook and loop tab. Replace the back pad if desired.



## Mounting a Single Cylinder or Twin Cylinders using Nuts and Bolts

To bolt a single cylinder or twin cylinders to the WTX harness, an Apeks back plate must be inserted into it. Ideally, the bolts on a single tank attachment kit or on a set of twin bands should be 11 inches (28 cm) on center. Remove the back pad from the WTX harness. Insert the bolts through the appropriate grommets on the bladder, and through the appropriate grommets on the WTX harness. Secure with flat washer and nut.



## Adjusting the Crotch Strap

The crotch strap is adjusted by moving the 2 inch webbing through the 3-bar slide near the back. The crotch strap should be tried on and adjusted while wearing your exposure suit. The strap should be lightly snug but not so snug as to prevent you from raising your arms above your head. Excess strapage can be cut with scissors and the end burned with a lighter to prevent unraveling, or it can be tucked into the elastic retainer loop.



**Note:** Do not cut the excess strapage so short that you cannot enlarge it in the future to compensate for a thicker exposure suit.

## Customizing the Shoulder Hardware

### *To open up the shoulder webbing:*

1. Remove epaulets from the shoulder strap webbing.

2. Unweave webbing from 3-bar plastic slide and rectangular plastic loop.



3. Remove 3-bar plastic slide from webbing. Pull webbing out from sewn-in shoulder strap loop.
4. You now have the ability to add or remove hardware according to your needs.

### *To secure the shoulder webbing:*

1. Weave webbing back through sewn-in shoulder strap loop.
2. Install 3-bar plastic slide to webbing so that it's positioned about an inch below rectangular plastic loop

3. Insert webbing, back to front, through rectangular plastic loop and back around toward 3-bar plastic slide.



4. Weave webbing through 3-bar plastic slide and tighten, making sure that there is at least 0.5 inches of excess webbing extending past the 3-bar plastic slide.



**CAUTION:** Failure to correctly reassemble shoulder strap could cause strap assembly to come undone during a dive, resulting in loss of equipment.

## Positioning Waist Buckle

The metal waist buckle can be mounted on either side of the waistband.

If you would like to switch the buckle to the other side, weave the buckle as shown. Don the WTX harness with cylinder(s) and your normal exposure suit. Run the 2-inch waistband through the buckle so that the buckle will be positioned where you like.



Excess strapage may be cut with scissors and the end burned with a lighter to prevent unraveling.



**Note:** Do not cut the excess strapage so short that you cannot enlarge it in the future to compensate for a thicker exposure suit.

## Attaching the MP Hose to the First Stage

Apeks recommends that you bring your buoyancy compensator, together with your regulator, to your authorized dealer for the installation of the medium pressure (MP) inflator hose and other accessories. The retailer can also answer any questions you may have pertaining to the information in this manual. If it is not possible to return the BC with your regulator to your authorized dealer, you may install the MP quick disconnect inflator hose by carefully performing the steps in the following procedure.

**⚠ WARNING: DO NOT connect the inflator hose to a high pressure (HP) port (greater than 200 psi / 14 bar). This may cause the hose to burst when pressurized, which can result in serious injury. If you are unsure which regulator port is medium pressure (MP) or high pressure (HP), consult your regulator owner's manual or your dealer before attaching the hose.**



1. Remove the inflator hose from the power inflator body by gripping the grooved sleeve over the quick disconnect coupling with your thumb and forefinger and sliding the sleeve back.

2. Remove the port plug from a medium pressure (MP) port on the regulator using an appropriately sized wrench.



3. Check to ensure the o-ring is present and in good condition. Screw the threaded end of the hose into the port. Tighten to 40 in/lbs (46 kg/cm) with a 9/16" wrench.



## USING YOUR WTX SYSTEM

### Predive Inspection

Before each use, the BC must be given a thorough visual inspection and functional test. NEVER dive with a BC that shows signs of damage to its bladder or valving until it has received a complete inspection and service from an authorized dealer.

#### ***Inspection Checklist:***

1. Connect the power inflator to a source of clean, compressed air, via the MP quick disconnect hose. Depress and release the inflator button intermittently to ensure that the airflow is unobstructed, and that the airflow stops completely when the button is released.
2. Manually operate the overpressure relief (OPR) valves by pulling on the attached ball and cord to release air from inside the BC, and then fully inflate the BC until the OPR valve opens. Examine the operation of the OPR valves by repeatedly inflating the BC to ensure that they open to relieve excess pressure, yet close immediately afterward to allow the bladder to remain taut and fully inflated.
3. Check the function of the oral inflator button and overpressure relief/ manual dump valve (***see Deflation Methods on page 26***) to ensure a rapid and unobstructed exhaust from each valve. Fully inflate the BC once again, and disconnect the Power Inflator from the compressed air supply and listen closely for any leaks.



**WARNING:** If you can hear any leaks, or if the bladder begins to deflate within 5-10 minutes, DO NOT attempt to use the BC until it has received service from an authorized dealer.



**Note:** If applicable, perform steps 1-3 above on the second bladder of the redundant bladder model.

4. Make a final check of the cylinder band's tension to ensure that it has not loosened due to stretching. Retighten if necessary.
5. Before entering the water, check both weight pouches to ensure that they are correctly fastened to the BC.



**WARNING: Loss of the releasable weight pouches can occur if the SureLock™ buckle mechanism is not properly engaged. Involuntary release of both weight pouches can cause a sudden increase in buoyancy causing a rapid ascent, and could lead to serious injury or death due to arterial gas embolism, decompression sickness, or drowning.**

## Donning & Adjustment Procedures

1. If you have the optional SureLock weight system on your WTX harness, remove the weight pouches from their holsters.
2. Loosen and disconnect the waist buckle and chest buckle.
3. Fully extend each shoulder strap to its maximum length by pushing straight up on the slide buckle.
4. While your dive buddy stabilizes the system behind you, place your arms through the harness shoulder straps as if you were putting on a jacket.
5. Place the free end of the 2" waistband webbing through the loop sewn into the front of the crotch strap. Fasten the waist buckle. It should be snug enough that the weight of the cylinders should rest on the lumbar region (lower part) of your back.
6. Connect the chest strap buckle. Pull on the free end of the strap to tighten. The chest strap should feel comfortable across the chest; it should not be overtightened so that it feels restrictive.
7. Bend forward at the waist and adjust the shoulder straps to a comfortable length by pulling on the shoulder strap D-rings.



**Note:** *Adjusting the shoulder straps too tightly will transfer the cylinder weight from the hips to the shoulders, restricting your arm movement and decreasing comfort.*

8. If necessary, readjust the waist buckle so that it is comfortably snug, but not restricting.

## Inflation Methods

### Oral Inflation

To orally inflate your BC, place your lips on the oral inflator mouthpiece (**Fig. 1a**) and exhale a small amount of air into the mouthpiece to purge any water that may still be in the housing. While continuing to exhale into the mouthpiece, depress the oral inflator button (**Fig. 1b**) to inflate the BC. Immediately after exhaling, release the oral inflator button to prevent air from escaping.

### Power Inflation

For the power inflator to operate, the medium pressure (MP) inflator hose must be connected. To connect the MP hose, grip the grooved sleeve at the connection fitting with your thumb and forefinger, and slide the sleeve back. Place the fitting over the quick disconnect plug (**Fig. 1c**), and firmly push inward while releasing the sleeve. Check to ensure that the hose is securely attached. After the hose is attached to the power inflator, pressurize the first stage regulator by slowly opening the cylinder valve.

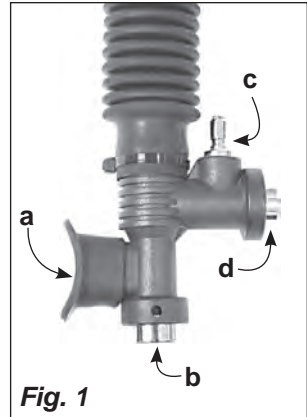

To inflate your BC with medium pressure air, depress the power inflator button (**Fig. 1d**). Do not hold the inflator button depressed continuously underwater, as this could cause you to become excessively buoyant. Instead, depress the button in short bursts until you become neutrally buoyant.



**WARNING: Do not rely on the power inflator as the only means to inflate your BC. It is important to practice the technique for orally inflating your BC so that you are prepared for any type of malfunction or out of air situation that could render the power inflator inoperable. You may otherwise be unable to achieve positive buoyancy in an emergency, which could lead to serious injury or death.**

## Deflation Methods

Throughout the course of a dive, it will be necessary to release air from the BC using one of the two methods described in the following instructions. Each method uses a valve that is in a different location. The method you choose at any time may depend on whether you are making your initial descent feet-first, head-first, or maintaining neutral buoyancy underwater. Always remember to utilize the valve that is at the highest point on the bladder, depending on your position in the water.

### **Deflation via Oral Inflator**

To deflate the BC using the oral inflator, lift the inflator body to its highest possible position (above the head). Press the oral inflator button (**Fig. 1b, previous page**) to start venting air. This method is most effective on the surface when starting the initial descent.

### **Overpressure Relief (OPR)/Dump Valves**

Each buoyancy cell is equipped with an over-pressure relief (OPR) / dump valve. Their primary function is to relieve excess pressure inside the cell but they can also be opened manually by pulling on the ball and cord assembly.

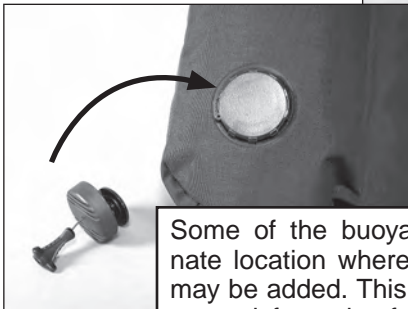
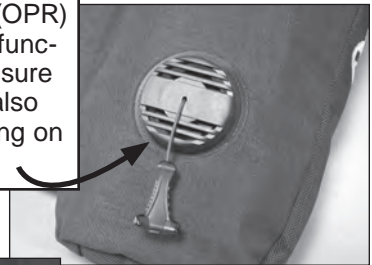

Some of the buoyancy cells offer an alternate location where an optional dump valve may be added. This alternate location comes capped from the factory. A universal OPR/dump valve kit may be ordered from your dealer (p/n 42754). Instructions for installation are included in the kit.

To dump air as quickly as possible, always use the dump valve at the highest point in the water column. For example, the lower valve works best while making a head-first descent, or swimming in a face-down position.



**CAUTION:** The proper function of the overpressure relief valve is vital to prevent damage to the BC bladder. Unauthorized service or tampering may render this valve inoperable, and could cause the bladder to leak or burst. This type of damage is not repairable, and is not covered under warranty.



**WARNING:** Most training agencies recommend that you should descend in an upright, feet-first position, in order to maintain a slower and more controlled descent. This is especially true if you experience difficulty equalizing your ears, or if you are descending in low visibility conditions.

## Postdive Care & Maintenance

With proper care, your BC will provide many years of reliable service. The following preventive maintenance must be performed to extend the life of your BC:

1. Avoid prolonged exposure to direct sunlight and extreme heat. Nylon fabric can quickly fade when exposed to the sun's ultraviolet rays, and extreme heat may damage the welded bladder seams.
2. Avoid repeated or prolonged use in heavily chlorinated water, which can cause the BC fabric to discolor and decay prematurely.
3. Do not allow the BC to chafe against any sharp objects or rough surfaces that could abrade or puncture the bladder. Do not set or drop heavy objects such as block weights on the BC.
4. Avoid any contact with oil, gasoline, aerosols, or chemical solvents.
5. To preserve the life of the bladder, rinse it inside and out with fresh water after every day of use, using the following procedure:
  - a) Pressurize the power inflator with medium pressure (MP) air via the MP hose.
  - b) Using a garden hose, direct water through the oral inflator mouthpiece to flush the interior of the bladder, and then thoroughly rinse the exterior of the BC.



**CAUTION: Before rinsing, ensure that the power inflator is pressurized with air. This will prevent debris and contaminants from entering the valve mechanism if the inflator button is accidentally depressed.**

- c) Completely drain the bladder of water, either through the oral inflator or through the overpressure relief valve.
  - d) Inflate the BC, and allow it to dry inside and out. Then store it partially inflated, away from direct sunlight, and in a clean, dry area. Do not store the BC in an enclosed space, such as a car trunk, where temperatures may fall below 0°F (-18°C) or rise above 120°F (49°C).
6. Thoroughly rinse the SureLock™ weight release mechanism, including the female receptacle and male insert. Visually inspect both parts of the mechanism to make sure they are free of any debris (sand, salt, silt, rocks, etc.) that could hinder the smooth operation of the SureLock™. Connect and release the SureLock™ mechanism several times to ensure proper operation.

## DEALER INSPECTION & SERVICE



**WARNING: DO NOT attempt to perform any disassembly or service of your BC. Service requiring disassembly must only be performed by a factory-trained Apeks technician. To obtain service or repair, such as power inflator service or replacement of the bladder, see your local authorized dealer.**

1. It cannot be assumed that the BC is in good working order on the basis that it has received little use since it was last serviced. Remember that prolonged or improper storage can still result in internal corrosion and/or deterioration of o-ring seals and valve springs, as well as bladder seam degradation.
2. It is imperative that you obtain prescribed dealer service for your BC at least once a year from an authorized dealer, including a general air leak inspection and complete overhaul of the power inflator and OPR valve. Your BC may require this service more frequently, depending on the amount of use it receives and the environmental conditions it is used in.
3. If the BC is used for rental or training purposes in salt, chlorinated, or silted fresh water, it will require prescribed dealer service every three to six months. Use in chlorinated water will greatly accelerate the deterioration of most components, and require more frequent service.
4. **DO NOT** attempt to perform any disassembly or overhaul service of your WTX product. Doing so may cause the BC to dangerously malfunction, and will render the warranty null and void. All service must be performed by an authorized Apeks Dealer.



***NOTE: IT IS IMPORTANT TO OBTAIN PRESCRIBED DEALER SERVICE FOR YOUR WTX SYSTEM AT LEAST ONCE ANNUALLY, FROM AN AUTHORIZED APEKS DEALER. YOUR PERSONAL SAFETY AND THE MECHANICAL INTEGRITY OF YOUR WTX SYSTEM DEPENDS ON IT.***



## WARRANTY INFORMATION

All warranty transactions must be accompanied by proof of original purchase from an authorized Apeks Dealer. Be sure to save your sales receipt, and present it whenever returning your BC for warranty service.

### Limited Lifetime Warranty

Warranty coverage on buoyancy compensators covers the product throughout its useful life, subject to the conditions listed below and utilizes a pro-rated replacement policy\*.

Apeks warrants to the original purchaser for the useful life of the product, from the date of purchase, that the product will be free from defects in materials and workmanship, provided that it receives normal use, proper care and prescribed dealer service subject to the limitations listed below. The Limited Lifetime Warranty is extended only to the original purchaser for purchases made from an Authorized Apeks and is not transferable. This warranty is limited to repair or replacement only at the discretion of Apeks.

### Limitations

Warranty coverage does not extend to damages caused by improper use, improper maintenance, neglect, unauthorized repairs, modifications, accidents, fire, casualty or normal wear and aging.

Cosmetic damage(s), such as scratches, nicks and fraying are not covered under warranty except when the product is new, out of the original packaging.

This warranty does not extend to equipment used for rental, commercial or military purposes.

This warranty covers products purchased in the USA. For warranties that may apply elsewhere, please contact your local representative.

### \*Product Replacement on a Prorated Basis

Products under the Limited Lifetime Warranty that malfunction due to material or manufacturer defects that have also had a significant amount of use will be replaced on a prorated basis. Prorating will be determined by a percentage factor based on the condition of the product and how long the product was used prior to the warranty claim. This can be useful to evaluate Limited Lifetime Warranty claims since the warranty period is for the "useful life of the product" and not a set length of time. The following guidelines should be used in determining what prorated percentage will be used.

Note: This can be a subjective evaluation. Fair and reasonable judgment should be used.

Prorated values for products sold at retail	Apeks Pays	Customer Pays
Like new and less than 2 years old	100%	0%
Slightly used and less than 5 years old	75%	25%
Very used and/or more than 5 years old	50%	50%
Worn out	0%	100%

This warranty gives you specific legal rights. You may have rights which vary from state to state and country to country.

AQUA LUNG/APEKS DISCLAIMS AND EXCLUDES ANY LIABILITY FOR INCIDENTAL OR CONSEQUENTIAL DAMAGES. SOME STATES IN THE U.S. AND CERTAIN FOREIGN COUNTRIES DO NOT ALLOW EXCLUSIONS OR LIMITATIONS OF LIABILITY FOR INCIDENTAL OR CONSEQUENTIAL DAMAGES, SO THIS MAY NOT APPLY TO YOU.



**WARNING: It is dangerous for untrained and uncertified persons to use the equipment covered by this warranty. Therefore, use of this equipment by an untrained person renders any and all warranties null and void. Use of SCUBA equipment by anyone who is not a trained and certified diver, or receiving training under the supervision of an instructor, could lead to serious injury or death.**





wtx series  
owner's manual

